

TXONU20

Features:

- Automatic Level Control
- High Output level
- Easy Installation & Adjustment
- Service Interruption Prevention during adjustments
- DFBI Return Path Transmitter module
- Compact Die-cast Aluminium Housing
- Excellent Surge And Transient Protection

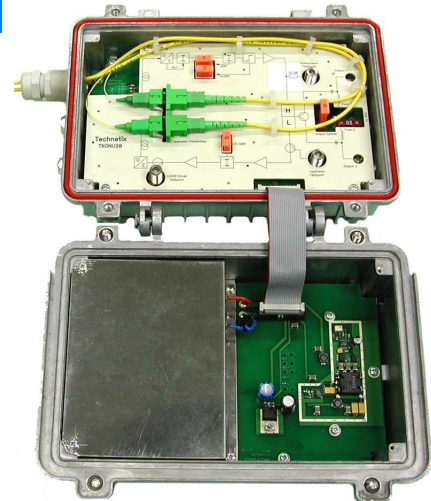

Overview

The optical node TECHNETIX TXONU20-FTTLA is a low cost, high performance optical node which can be implemented economically in all new and existing cable TV system architectures. The node has been designed for simplicity of installation and operation. No expensive optical test equipment is needed. A LED-bar gives an indication of the received optical power in steps of 2dBm. There is no need for any optical measurement device. For a received optical power between -6dBm and +2dBm, the output level will remain constant at 2 X 114dBμV.

The input pigtail is standard equipped with a SC APC 8° connector. Other connectors are available on demand. A hybrid with integrated PIN diode is used to convert the optical in an electrical signal. The RF signal at the output is adjustable both in level and tilt using standard JXP plug-in attenuators. A service interruption prevention facility is included to avoid any signal interruption during node adjustment. The node can used a number of different powering options.

Specifications

V1 feb 26, 2008

	Port	Range	Min	Typical	Max	Units	Remark	Margin
Connectors	RF in			5/8"				
	RF Out			5/8"				
	Optical			SC/APC 8°			11	
Temperature Range	Within the Specifications		-20		+60	°C		
	Functional		-20		+70	°C		
Equipment Approval								
Mechanical	Dimensions	L x B x H		230 x 180 x 100		mm		
	Weight			1.15		Kg		

Ordering Information

TXONU20

Article number:

TXONU20-FTTLA

Block diagram TXONU20

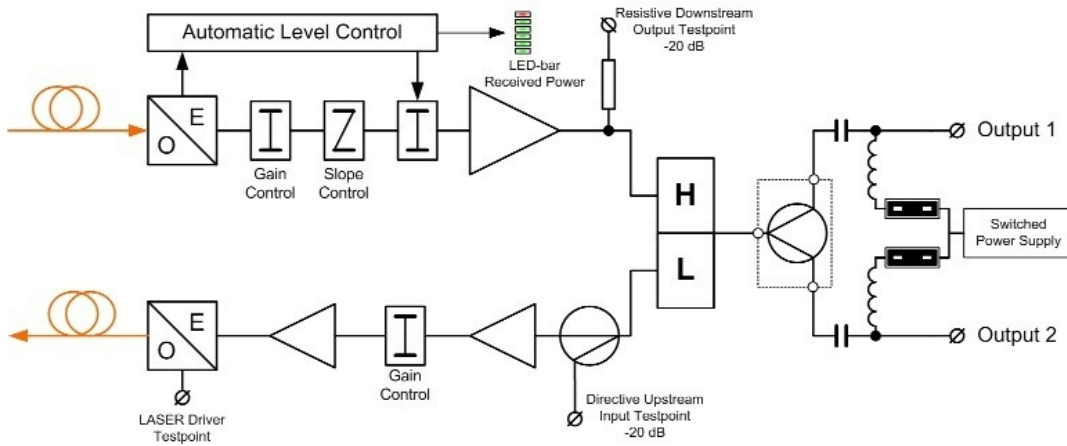

	Port	Range	Min	Typical	Max	Units	Remark	Margin
Screening Effectiveness	-	30 MHz < F < 300 MHz	75	85		dB	10	
		300 MHz < F < 470 MHz	75	85		dB	10	
		470 MHz < F < 862 MHz	65	75		dB	10	
Power Supply	Voltage		30		60	VAC	9	
	Consumption			26		W		
Testpoint	Downstream			-30 +/- 0,5		dB		
	Upstream			-20 +/- 0,5		dB		
RF	Frequency range		85		1000	MHz		
	Flatness			+/- 1		dB		
	Maximum Output level			2 x 114		dB μ V	1	
	Optical Input level		-6		+2	dBm	2	
	Impedance			75		Ohm		
	Return Loss			>16		dB		
	Gain Control			JXP atten.		dB	3	
	Slope Control			JXP atten.		dB	3	
	C/N			53		dB	4	
	CSO			-60		dBc	5	
Optical	CTB			-55 / 60		dBc	5	
	Wave Length		1290		1600	n m		
	Detector Type			PIN Diode				
	Max. Optical Power			2,0		mW		
Return Path	Type of Fiber			Single Mode				
	Return Loss			>45		dB		
	Laser Type			DFBI				
	Wave Length			1310 (+/-10)		n m	7	
	Optical Power			2,0		mW		
	IM 2,WC			-50		dBc	6	
	IM 3,WC			-69		dBc		
	Drive Level @ 5%			61		dB μ V		
	OMI							
	Drive Level @ 2,5%				55		dB μ V	
Indicators	OMI							
	Level TP @ 5%				96		dB μ V	
	OMI							
	CNR 2,5 OMI				52		dB	8
	Power On	Green LED (outside)						
	Low Level	Red LED (outside)				-6	dBm	
	In Range	Green LED (outside)	-6			+2	dBm	
	High Level	Red LED (outside)	+2				dBm	
Level indication	LED-bar in 2dBm steps (inside)	-6			+2	dBm		

Remarks	
1	RF Output level for Optical input between +2dBm and -6dBm and for OMI of 4,5%
10	Transfer impedance method according IEC 60728-2 (5-30 MHz) Absorbion clamp method according IEC-60728-2 § 4.4 (30-862 MHz)
11	Other types available (FC/APC, E2000, LC, ...)
2	Automatic Level Control Range
3	Standard Values 0/3/6/9 dB (JXP type)
4	C/N 53 dB for 0 dBm at the input of the Receiver
5	60dBc for 42 CENELEC channel Plan and 2 x 112 dBuV with tilt of 10dB 55dBc for 42 CENELEC channel Plan and 2 x 114 dBuV with tilt of 10dB
6	CWDM optional
7	Measured with 5% OMI per carrier
8	5dB loss, BW 600 kHz
9	Sine / Square Wave Form