

# mediaMAX EVO

User's Manual (English)



## INDEX

1 Introduction.....	5
2 Recommendations for best use of <b>mediaMAX EVO</b> .....	6
3 Package contents .....	7
4 Technical specifications.....	8
5 Meter's power supply.....	10
6 Front panel description .....	11
6.1 Main keypad description .....	12
6.2 Click rotary wheel .....	17
7 Status bar.....	18
8 Connections .....	21
9 Operating with the meter .....	22
9.1 First time operation.....	22
9.2 Meter starting up .....	22
9.3 RF cable connection .....	23
9.4 TV standard setup .....	23
10 Measurements .....	24
10.1 Terrestrial signal measurement.....	25
10.1.1 Frequency band selection .....	25
10.1.2 Use spectrum mode to spot a signal .....	26
10.1.3 Measurement selection.....	27
10.1.4 Make measurements.....	28
10.1.5 Picture representation .....	29
10.2 Satellite signal measurement .....	33
10.2.1 Frequency band selection .....	33
10.2.2 Supply LNB power.....	33
10.2.3 Use spectrum mode to spot a signal.....	35
10.2.4 Measurement selection.....	36
10.2.5 Make measurements .....	37
10.2.6 Picture representation .....	38
10.2.7 DiSEqC switch.....	42
10.3 Cable signal measurements .....	43
10.3.1 Frequency band selection .....	43
10.3.2 Use spectrum mode to spot a signal.....	43
10.3.3 Measurement selection.....	44
10.3.4 Make measurements .....	46
10.3.5 Picture representation .....	47
10.4 FM signal.....	51
10.4.1 Frequency band selection .....	51
10.4.2 Signal measurement.....	52
11 Programs .....	53
11.1 Edit programs.....	53
11.1.1 Create program.....	53
11.1.2 Save a program .....	55
11.1.3 Delete a program .....	56
11.1.4 Load program from USB .....	57
11.1.5 Save program to USB .....	57
11.1.6 Navigation by program.....	58
12 Key "fav" functions .....	58
12.1 Configuration.....	58
13 Autoscans function .....	59

14 Datalogger.....	60
14.1 New measurement .....	61
14.2 Watching the measures.....	63
14.3 Delete measures .....	64
14.4 Export measures.....	65
14.5 Group management .....	65
14.5.1 Creating a group.....	65
14.5.2 Copy a group .....	66
14.5.3 Delete a group .....	67
14.5.4 Add a program .....	68
14.5.5 Delete a program.....	69
14.5.6 Group options.....	70
14.5.6.1 Name of the group .....	70
14.5.6.2 Pause in FM Band.....	71
14.5.6.3 Pause in Band switching .....	71
14.5.6.4 Kind of measure.....	72
14.5.6.5 Repeating .....	72
14.5.6.6 Period .....	73
14.5.6.7 Temporize measurements.....	73
14.6 Disk of working .....	74
15 Security copy .....	75
15.1 Copya II to USB.....	75
15.2 Restore copy from USB .....	76
16 Satellite finder.....	78
16.1 Identify the satellite .....	78
16.2 Searching a satellite.....	79
16.3 Options.....	80
16.3.1 Add a new satellite .....	80
16.3.2 Delete satellites.....	81
16.3.3 Import satellites .....	81
16.3.4 Export satellites .....	82
16.3.5 Show satellites .....	82
16.3.6 New parameters satellite.....	83
ANNEX 1. Viewer of EVO Datalogger .....	84
ANNEX 2. Channels plan .....	87
B/G CCIR STANDARD .....	88
L/L' STANDARD .....	90
D/K/K'/DK PAL STANDARD .....	91
I STANDARD .....	92
M/N STANDARD .....	93
B/B Australia STANDARD .....	94

## 1 INTRODUCTION

The **mediaMAX EVO** is the first measurement device of the new advanced generation of Fte maximal field strength meters.

This new **mediaMAX EVO** has been designed with a very new concept in order to offer improved technical features, higher functionality, high precision on measurement procedures, improved on screen graphics (OSD), smaller and compact size and easiness for use it. All these features render the current meter an essential device for telecommunications installers and professional.

Some of the main features are hereafter explained:

- Measure of analog multistandard terrestrial (AMTV) and satellite signals (FMTV)
- Sync pulse for analog signals
- Measure of digital terrestrial (DVB-T), satellite (DVB-T) and cable (DVB-C) signals
- Analog and digital image representation on colour TFT screen
- Improved user interface
- Friendly On Screen Display (OSD)
- Simultaneous representation of measure, spectrum and image for the reference signal
- Datalogger
- TFT 5" Color Monitor
- Compact and light design (3,9 Kg)
- Improved connectivity (USB, input and output Audio/Video minijack,...)
- High battery life (till 4,5 hours without LNB)

With all the above features, the **mediaMAX EVO** field strength meter will allow the user to analyze all television signals, solving every problem on a television, satellite or cable installation.

### 2 RECOMMENDATIONS FOR BEST USE OF mediaMAX EVO

The aim of this manual is to provide the fundamentals of the operation of the field strength meters in order to make the best of it.

The **mediaMAX EVO** field strength meter is a portable devices, conceived for exterior use, with certain limitations:

- It is not advisable to use the strength meter under the rain; although it is water proof, it could be damaged if the water penetrates inside.
- It is recommended not to use the meter in case of extreme weather conditions, such as temperatures below 0 degrees or over 40 degrees centigrade
- Never use your meter as a standing support
- The mains power supply is designed for indoor use, so it must not be used outdoor. Always use the power supply adapter provided with your meter.

Please keep always in mind the following recommendations:

- Please note that the meter's battery is specifically designed for the device. An eventual replacement by any other, could cause a failure of operation, or even worse, a serious damage to the battery and to the meter.
- A field strength meter is a very sophisticated measurement device, sensitive to sudden temperature and humidity changes, and affected by impacts and vibrations.
- Never open the meter by yourself. Every manipulation inside the device requires specific instruments. An unqualified manipulation may cause serious damage in the meter.
- Always handle the meter with care, it is a high technology device that may be damaged in case of improper use.
- Please do not obstruct the ventilation orifices situated on both sides of the meter, in order not to overheat the system.
- It is important not to use poor quality connectors, nor right angle connectors and different adapters, since all these elements degrade the quality of the signal arriving to the meter's RF-IN socket.

### 3 PACKAGE CONTENTS

Please check the contents of your package in the following list:

- Field Strength Meter
- Bag
- Mains power supply 20V 2,5Amp.
- Mains power cable for the power supply
- Adapter F-F female. Please note that this is a high quality adapter. Do not replace it by any other, since the frequency response is specific for this system. In case it's necessary replace it, we advice to use ref. FBU-FBU Fte maximal
- User's quick reference guide
- Document providing a list of the meter's components, as well as the information concerning - the meter's calibration.

Please do not throw away the original box, it is specially designed for protecting your meter. You might find it useful for transportation, or in case you wish to have it calibrated in the future.

## 4 TECHNICAL SPECIFICATIONS

### RF Standards

FM: 88-108 MHz

Terrestre: B/G (CCIR),

B/G DE, S band channels in Germany

B/G IT, III band channels in Italy

M (PAL)

L/L' (France)

I (UK)

D/K/K' (O.I.R.T.)

M/N (USA and Japan)

BB\_AU (Australia)

D/K PAL

Satellite: C and Ku bands

### Monitor

Type: 5" (14cm) TFT color

Color standards: PAL, SECAM and NTSC

Audio amplifier: 1W inside the speaker

### Programs

Memories: 1000 programs could be saved inside the internal memory.

Data Logger: 4000 measures could be saved inside the internal memory. These saved values could be measures, spectrum and syncro pulse.

These values could be downloaded through USB port.

### LNC power supply

Voltage: 0, 5V, 13V, 18V, 13V+22Khz and 18V+22Khz (shown by OSD).

Max current.: 450 mA short circuit protected

DiSEqC: 1.2

### Auxiliary inputs / outputs

A/V: Minijack Audio/Video input and output

RS-232: Serial port for PC connection

USB: Host Driver USB 2.0

### Power Supply

Battery: Lítio - Ion (90 W/hour)

Battery level ind.: Continuous control on OSD

Battery life: 4.5 h without LNB power supply

Charging time: Aprox. 5 hours for 100% (it depends on battery previous charge)

External: 20V / 2.5A

### Mechanics

Dimensions: 280x130x220mm + bag

Weight: 3,9 Kg.

### Frequency

Range: 5-862 MHz and 900-2150 MHz

Tuning: Continuous in full band

Steps: 50KHz (terrestrial band) and 500 KHz (satellite band)

Audio range on analog satellite: 4.5-9 MHz

### Input

Impedance: 75 Ohms

Connector: "F" type (male) (+FBU-FBU adaptor)

Protection:  $\pm 50$  VDC, 130dB $\mu$ V (3V RMS)

Attenuator: 0 - 60dB, AUTO range mode selectable

### Spectrum

Bands: 5-47 MHz / 47-862 MHz / 900-2150 MHz

Display mode: Horizontal sweep and logarithmic amplitude

Marker: Unical

Span: Full, 500, 200, 100, 50, 20 or 10 MHz

Resolution filters: 2 MHz, 1MHz or 200 KHz

**Analog signals:** Level, Video/Audio level, C/N, sync pulse

Range: TV: 20 - 125 dBuV

SAT: 30 -125 dBuV

Units: dBuV, dBmV o dBm

Accuracy:  $\pm 1.5$  dB @ 25°C

Acoustic signal: Audio frequency proportional to signal level

## Digital

### QPSK

Measurements: Power, CSI, BER before and after Viterbi, non recovered errors, C/N, MER

Standard: DVB-S and DSS

### COFDM

Measurements: Power, CSI, BER before and after Viterbi, non recovered errors, MER

C/N

Modes FFT: 2K, 8K and AUTO

Guard intervals: 1/4, 1/8, 1/16, 1/32 and AUTO

Internal modulations: 64 QAM, 16QAM and QPSK

### QAM

Measurement: Potencia, CSI, BER, paquetes erróneos, MER

Modulation: 16, 32, 64, 128, 256 QAM

### MPEG2 decoder

FTA (Free to Air) program list

It shows NIT, PID Audio-Video and PCR

### 5 METER'S POWER SUPPLY

The field strength meter may receive its power supply via its internal batteries or using the external power supply provided with the meter.

The **mediaMAX EVO** includes a Li-ion 90W/hour battery, with a charged life over 4,5 hours without LNC power supply.

In order to charge the battery, please connect the 20V 2,5A power adapter output to the meter after having checked that it is turned off. The LED indicating battery charge will blink during charge. At the end of the charge cycle the LED will stop blinking and will stay continuously ON.

Meter's battery could be charged with the device switched on or switched off.

Important: it's highly recommended to charge the battery only when it has been completely used. Moreover, in order to have a 100% full charged battery, it could be necessary to charge it at least for 5 hours with the meter switched-off.

## 6 FRONT PANEL DESCRIPTION

The **mediaMAX EVO** front panel presents the following appearance:

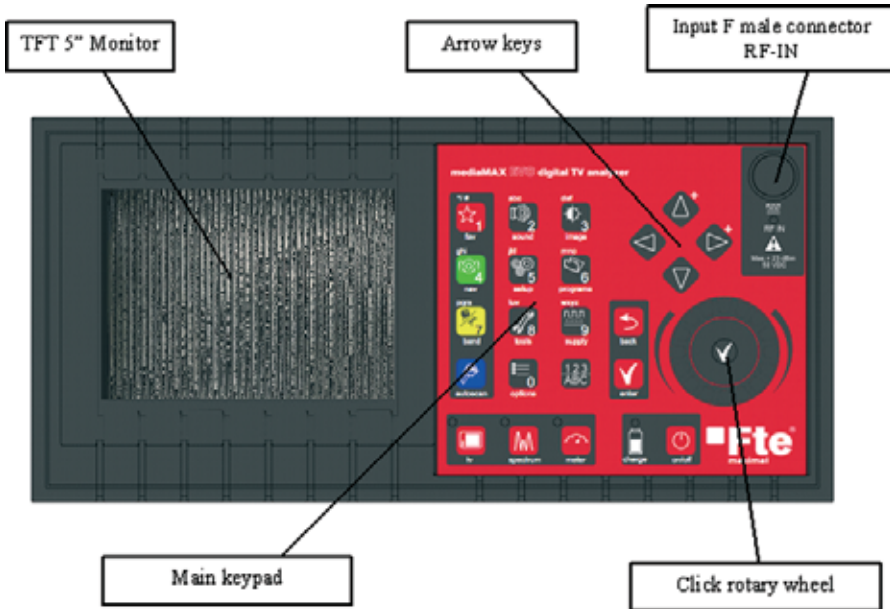

The front panel of the test equipment is made of 5 main parts:

- 1.- **Monitor.** It displays the OSD menu that allows to navigate through the different options to display the spectrum, measurements, pictures, etc.
- 2.- **Click rotary wheel.** It allows to navigate easily through the options of the OSD menu, just turning to the left or right of the wheel. It's also possible to confirm the selected option doing a click at the center of the wheel.
- 3.- **Arrow keys.** These four arrow keys have a similar function than the rotary wheel. They allow to navigate up and down through the OSD menu. Moreover the arrow keys allow to increase or decrease different values as span, volume,... depending on the main mode currently selected.
- 4.- **Main keypad.** This keypad is composed of several keys with different functions: on/off key, band key, menu keys,... Some of these keys make part of a numerical keypad that can be used to enter the frequency value, channel or program value.
- 5.- **RF-IN connector.** F male connector for antenna signal cable.

## 6.1 MAIN KEYPAD DESCRIPTION

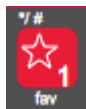

**fav** By default, to switch from an Analogue carrier to a Digital one. It can be configured with other functions.

With numeric entry active it is #1.  
With alphabetic entry active, it is \* / #



**sound** Audio menu. The options are the following:

- Volume (Level 0-100%)
- Audio type (Audio/Buzzer): Selecting the type of audio in "Buzzer", the speaker will buzz relative to the level of the signal received. On the top status bar will appear the following icon.

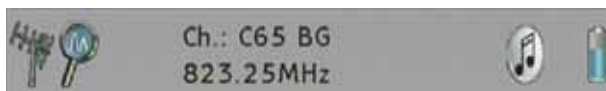

If the Buzzer option is selected, the audio of the channel will be substitute by the buzz.

- Carrier frequency: (FM, 5.5, 6.5, v4.5-9)

With numeric entry active it is #2.  
With alphabetic entry active, it is a b c



**image** Picture menu. The options are the following:

- Brightness: 0-100 %
- Contr: 0-100%
- Color: 0-100%
- Hue: 0-100%
- External Video: Off / On. It will allow enable/disable the input of the external video.

**NOTE: Once selected the external video input, the meter only will leave activated the keys "Sound" and "Image", allowing only watching on TV Mode, and disabling the spectrum and measures mode.**

With numeric entry active it is #3.  
With alphabetic entry active, it is d e f



**nav** Setup the navigation mode: by frequency, by channel (it is available only in terrestrial band), by program, or by group.

With numeric entry active it is #4.  
With alphabetic entry active, it is g h i



## setup

Setup meter menu. The options are the following:

### 1. System:

- Language
- Beep: key's beep
- Favorite key config
- System info
- Factory default
- Firmware upgrade
- Update Autoscan

### 2. Power off modes:

- On/Off key: (stand by / switched off)
- Auto stand by (battery): (Never/ 1min / 2min / 3min / 4min / 5 min / 10 min /15 min 30 min / 60 min )
- Auto swith off (battery): (Never/ 1min / 2min / 3min / 4min / 5 min / 10 min /15 min 30 min / 60 min / 120 min)
- Auto stand by (DC): (Never/ 1min / 2min / 3min / 4min / 5 min / 10 min /15 min 30 min / 60 min )
- Auto switch off (DC): (Never/ 1min / 2min / 3min / 4min / 5 min / 10 min /15 min 30 min / 60 min / 120 min )

### 3. RF:

- Units: (dbuV, dBmV, dBm)
- Terrestrial standard: (B/G, B/G DE, B/G IT, L/L, M, NTSC, MPAL, D/K, I, BB\_AU, D/K PAL)
- Cable standard (B/G, B/G DE, B/G IT, L/L, M, NTSC, MPAL, D/K, I, BB\_AU, D/K PAL)
- Satellite local ocs: (IF, C, KU, K9750, K10000, K10600, K10700, K10750, K11250, K11300, K11325)
- Cable band: (Active, hidden)
- Band navigation: (Linear, curl)
- Autoscan Standard: (All, Selected) For scanning all the standards or only the current one. When all the standards are being scanner, the first one scanner will be the current one.

### 4. Backup: Function to restore the system:

- 1) Copy all to USB: Function to make a security copy into a USB device.
- 2) Restore copy from USB: Function for restoring a copy of security from a USB device.

Depending on the type of file, there are different options to restore: All, Programs, Autoscan, Satellites or Data logger).

### 5. Clock: Time and date setup

With numeric entry active it is #5.

With alphabetic entry active, it is j k lz



- programs** Programs menu. The options are the following:
- Create program
  - Save program
  - Delete programs
  - Load programs from USB
  - Save programs to USB

With numeric entry active it is #6.  
With alphabetic entry active, it is m n o



- band** Band selection:
- Terrestrial 47-862 MHz
  - Satellite IF: 900-2150 MHz
  - Cable 5-862 MHz

With numeric entry active it is #7.  
With alphabetic entry active, it is p q r s



- tools** Tools menu:
- Datalogger
  - Satellite finder

With numeric entry active it is #8.  
With alphabetic entry active, it is t u v



- supply** Power supply menu:
- RF IN voltage: (Off, 5V, 13 V, 18V)
  - Tono 22 KHz: (Off, On, Auto)
  - DiSEqC switch (Off, A, B, C, D)
  - RF voltage on power up: (Off, On)

With numeric entry active it is #9.  
With alphabetic entry active, it is w x y z



- autoscan** This function allows tuning the selected carrier automatically, it is, it carries out an auto scanning of the carrier. In case the carrier is not found, an error message will be displayed.



## options

Signals setup options:

1. **Carrier mode:** (Analog, digital)

2. **Digital modulation** (it depends on selected band)

### COFDM Setup:

1. Mode: (Auto, 8K, 2 K)
2. Spectrum inversion: (Auto, On, Off)
3. Guard interval: (Auto,  $\frac{1}{4}$ ,  $\frac{1}{8}$ ,  $\frac{1}{16}$ ,  $\frac{1}{32}$ )
4. Bandwidth: (Auto, 8 MHz, 7 MHz, 6MHz)
5. Priority: (High, low)
6. Offset: (Auto, 0, +125, -125, +166, -166, +333, -333, +500, -500)

The default value for Span in Terrestrial is 50 MHz

### QPSK Setup:

1. Symbol rate: (1000-50000)
2. Mode: (DVB, DSS)
3. Spectrum inversion: (Auto, On, Off)

The default value for Span in Satellite is 100 MHz

### QAM Setup:

1. Symbol rate: (870-7000)
2. Spectrum inversion: (Auto, On, Off)
3. Constellation: (256, 128, 64, 32, 16)
4. Constellation display (Off, All, 1,2,3,4) To show the constellation diagram in measurement mode.

The Span value by default in cable is 50 MHz.

3. **DVB Service**

1. Mode: (Auto, Manual)
2. Video PIDs: (1-65535)
3. Audio PIDs: (1-65535)
4. PCR PID: (1-65535)
5. Program selection (only when tuned)

4. **Spectrum configuration**

1. Span: (10 MHz, 20 MHz, 50 MHz, 100 MHz, 200 MHz, 500 MHz, Full)
2. Resolution filter: (Auto, 0.2 MHz, 1 MHz, 2MHz)
3. Sweep resolution: (Max, High, Medium, Low)
4. Detector mode: (Peak, sample, auto): Choose detection mode option in "Peak" for analogue signals / Detection mode in "Sample" for digital signals / "Auto": mediamax EVO will choose it automatically depending on the kind of signal.
5. Marker values (Marker, Measure) To get the value of the marker in a punctual point (Marker) or the real value of the measurement of the channel (Measurement).

5. **Reference level** (Auto, 130 dB, 120dB, 110 dB, 100 dB, 90 dB, 80 dB, 70 dB)

6. **Group Name:** The name of the group stored in the Datalogger appears. Note: In case any group is created in the Datalogger, it won't be possible to navigate in group mode.

With numeric entry active it is #0.



123/abc

Numeric and alphabetic entry activator. When program mode selected, this key shows a menu for select directly one registered program.



back

Cancel or return to previous action without modifying.



enter

Confirm the selected option.



tv

Display the picture of the tuned channel on the TFT monitor. If selected channel is digital, the monitor will represent the picture of the first transponder / multiplex program



spectrum

Display the frequency spectrum on the monitor.



meter

Display the measurements values of the selected signal. The information depends on the signal type:

**Analog signals:** Level, C/N, audio

**Digital signals:** Power, C/N, Quality (CSI), BER before and after Viterbi, MER

**NOTE: with simultaneous activation of tv, spectrum and meter keys, is possible to display on the monitor spectrum, measurements and picture of the selected signal.**



Up / down  
arrow keys

Movement inside the OSD menu options. With digital signals, these keys allow to navigate through the different programs' pictures.



**Left / right  
arrow keys**

In picture mode, these keys allow to modify audio volume. In spectrum mode, they modify the span



on / off

Meter switch on-off

## 6.2 CLICK ROTARY WHEEL

The click rotary wheel is one of the main mediaMAX EVO controls. It manages in an easy way the navigation through the menu options. The actions of the wheel are the following three: left turn, right turn and click functions. Using them is possible to manage the whole OSD menu.



Turning the wheel, it's possible to go up and down through the different options of the menu. If the monitor is showing a spectrum with signals, the wheel movements will sweep the band. A short click on the wheel is interpreted as an OK (it confirms the selection); a long click cancels the action and goes out the OSD.

## 7 STATUS BAR

The status bar on top of the screen holds important information about meter status. It is always present, exception when in pure TV mode. It offers useful information about selected options, frequency, band, and battery status.

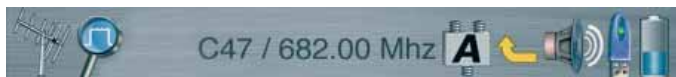

The following table shows the icon and the functions of each of them:

### Band

Information about the selected frequency band



Cable band (5-862 MHz)

Terrestrial band (47-862 MHz)

Satellite band (950-2150 MHz)

### Spectrum mode

Information about the selected spectrum mode and selected carrier



Analog mode

Digital model

Analog locked

Digital locked



## Power supply mode

Information about selected DiSEqC switch

Switch A

Switch B

Switch C

Switch D

## Satellite band and polarity

Information about satellite band and selected polarity

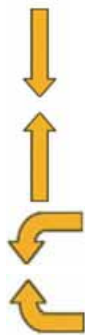

Vertical low

Vertical high

Horizontal low

Horizontal high

## User's Manual - mediaMAX EVO



Audio  
Information about audio status



Audio On

Audio Mute



Mode Buzzer



Mode FM



USB  
USB device connected



Batería  
It shows the real level of battery

## 8 CONNECTIONS

The meter front panel is equipped with a F-male high quality connector for the input coaxial cable. Connect the FBU-FBU adaptor before to connect the cable with the input RF signal.



On the right side, the meter is equipped with the following connectors:

- Audio/video mini-jack input connector
- Audio/video mini-jack output connector
- RS232-C DB9 serial port for updating and calibration operations
- USB2 port for technical support and uploading/downloading data
- Power supply connector

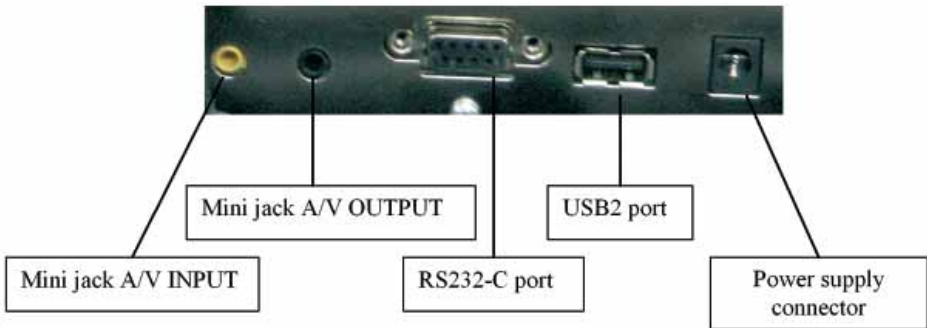

**NOTE:** For enabling/disabling the external video input you should push the key “3 Image” and navigate up to the “External Video” option. Please, select between On/Off to enable/disable the external video input through the Mini Jack A/V IN connector.

## 9 OPERATING WITH THE METER

### 9.1 First time operation

Before using your meter for the first time, please charge it completely (follow the indications in the chapter "Meter's Power Supply" (The battery is completely charged at the factory once the meter is finished, but the battery may be low when you purchase it).

### 9.2 Meter starting up

The **mediaMAX EVO** field strength meter is ready to begin work with it, therefore there is not any kind of installation to do for starting it up.

Press the ON/OFF key to switch on the meter. The power may be supplied through the mains or through the internal battery.

Once it has been switched on, the monitor shows a picture with Fte maximal logo, meter serial number and current firmware version. This information is important if customer service is requested for technical support regarding the meter.



MediaMAX EVO - S/N : 060806480050  
Fpga : 10.22 - Firmware : 5.21

## 9.3 RF cable connection

Connect the input RF coaxial cable to RF-IN F connector, once the FBU-FBU adaptor has been installed.



If necessary, for future replacement of the adaptor it's important to install a high quality adaptor that don't disturb input signal or create impedance problems. In this way it will be possible supply the meter with a real quality RF signal.

## 9.4 TV standard setup

It's important to setup the right TV standard in order to work correctly with the meter. It's possible also to setup the measurement units. To do it, press "setup" key on the front panel. After this, select "RF" option using the rotary wheel. Finally, select the second option "Terrestrial standard" and accept clicking on the wheel.

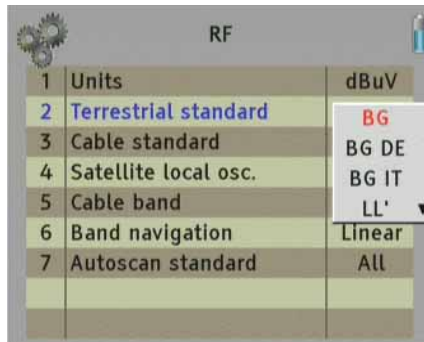

Measurement units could be selected pressing "setup" key and selecting "units" option. The available options are dBuV, dBmV and dBm based on user's preference.

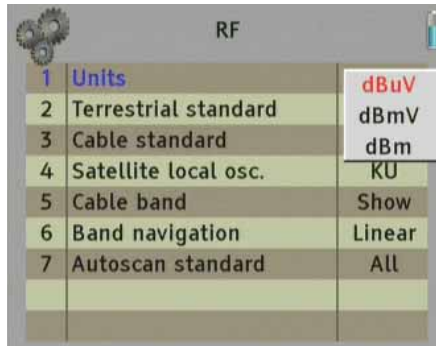

## 10 MEASUREMENTS

Some of the parameters while you are measuring are configured independently in each band (ter-sat-catv). These parameters are the following ones: Vrf, 22KHz, DiSeqC switch, Carrier Mode, RBW Filter, Spectrum Resolution, Detector mode spectrum, and Span of the spectrum.

The available measurements of **mediaMAX EVO** are the following:

### TERRESTRIAL BAND

#### 1.- Analog signal

1. Level
2. Audio
3. Video / audio difference
4. C/N
5. Sync pulse

#### 2.- Digital signal

1. Power
2. BER before Viterbi
3. BER after Viterbi
4. Quality (CSI)
5. C/N (digital measurement)
6. MER

### SATELLITE BAND

#### 1.- Analog signal

1. Level
2. C/N
3. Sync pulse

#### 2.- Digital signal

1. Power
2. BER before Viterbi
3. BER after Viterbi
4. Quality (CSI)
5. C/N (digital measurement)
6. Cable band
7. MER

### CABLE BAND

#### 1.- Analog signal

1. Level
2. Audio
3. Video / audio difference
4. C/N

#### 2.- Digital signal

1. Power
2. BER before Viterbi
3. Quality (CSI)
4. C/N (digital measurement)
5. MER

## 10.1 TERRESTRIAL SIGNAL MEASUREMENT

### 10.1.1 Frequency band selection

It's possible to know if terrestrial band it has been already selected. The status bar represents a logo (different for each band) that allow to know which band has been selected. There are three different options:



1. If logo shows a terrestrial antenna, then terrestrial band is selected.
2. If logo shows a coaxial cable, then cable band is selected.
3. If logo shows a satellite antenna, then satellite band is selected.

The status bar is hidden if only TV mode is selected. To make it appears, press "tv" key.

For terrestrial band selection, press one or several times "band" key until the monitor shows the message "Switching to terrestrial". The switching sequence is the following:

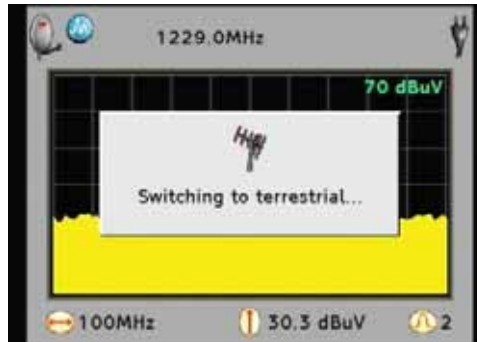
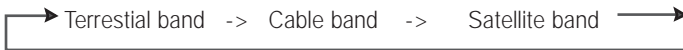

**Note:** If cable band is not necessary for the installer, there's a menu option that allow to hide it ("setup>RF>Cable band").

## 10.1.2 Use spectrum mode to spot a signal

To represent the frequency spectrum on the screen and spot a signal, press the **"spectrum"** key. When this selection is active, the green led over the key will be switched on.

In case of **"tv"** and **"meter"** keys are also switched on, the monitor shows a simultaneous representation of spectrum, picture and signal measurements. If these options are not necessary at the moment, it's possible to switch them off pressing the corresponding keys.

To identify a signal, to do it with a span of 50 MHz is advised (default value in terrestrial). For select it, use left and right arrows keys. The span current value is shown at the left bottom part of the monitor.

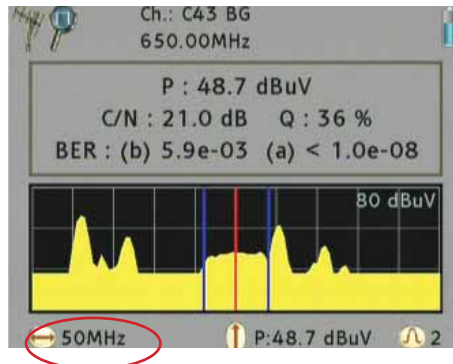

With the spectrum on screen, move the rotary wheel to sweep the frequency band to spot the target signal. In order to simplify the navigation through the terrestrial band, press the **"nav"** key for select channel mode or frequency mode.

- Channel mode allows to sweep the frequency band by channel defined in the standard
- Frequency mode allows to sweep the band normally by frequency with 50 KHz steps

## 10.1.3 Measurement selection

With the target signal identified, it's necessary to select the signal type (analog or digital). Press **"options"** key, select **"Carrier mode"** and there will be two different options:

1. **Analog**: if analog signal
2. **Digital**: if digital signal

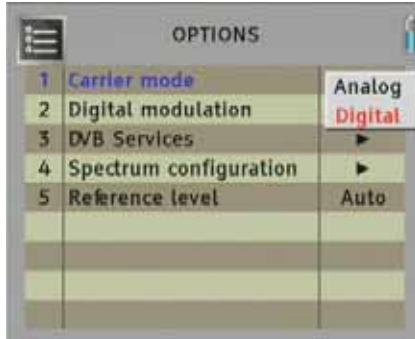

Select one of them and confirm clicking the wheel.

For digital terrestrial television signal, it is necessary setup signal parameters. Select **"Digital modulation"**. The advised configuration is setup the following options in automatic mode.

1. **Mode**: auto
2. **Spectrum inversion**: auto
3. **Guard interval**: auto
4. **Bandwidth**: auto
5. **Priority**: high
6. **Offset**: auto

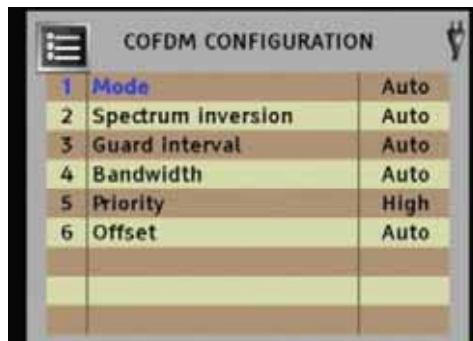

Press **"back"** key to turn back the main menu.

## 10.1.4 Make measurements

### 1.- Analog signals

To get analog terrestrial signal measurements, spot the signal as explained above and press “meter” key. It switches on the led over the key and the monitor and the monitor shows a screen with measures values.

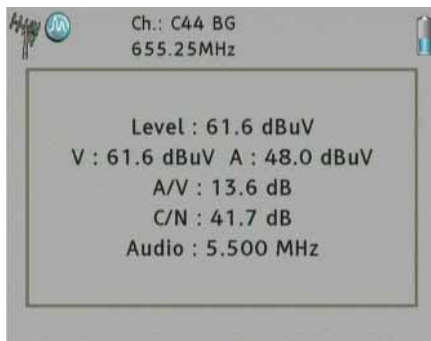

If “tv” and “spectrum” are selected (the led over these keys are switched on), the monitor shows a simultaneous representation of measurements, spectrum and picture. If these two options are not necessary, it is possible to cancel their representation pressing the corresponding keys.

The meter represents the following analog values:

- Level
- Audio
- Video / audio difference
- C/N

### 2.- Digital signals

To get digital terrestrial signal measurements, spot the signal as explained above and press “meter” key. It switches on the led over the key and the monitor and the monitor shows a screen with measures values.

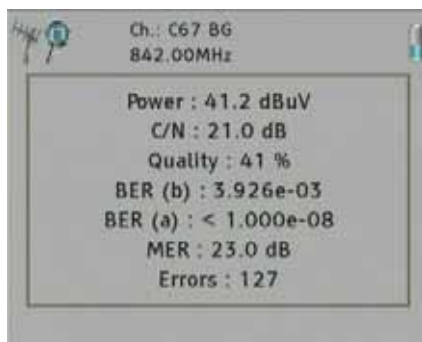

If **"tv"** and **"spectrum"** are selected (the led over these keys are switched on), the monitor shows a simultaneous representation of measurements, spectrum and picture. If these two options are not necessary, is possible to cancel their representation pressing the corresponding keys.

The meter represents the following digital values:

- Power
- BER before Viterbi
- BER after Viterbi
- Quality (CSI)
- C/N
- MER

### 10.1.5 Picture representation

The **mediaMAX EVO** meter is equipped with three different representation modes to show the information on the screen: **"tv"**, **"spectrum"** and **"meter"**.

There is a led over these buttons that inform the user which options are being currently used. At least one of them will be always switched on.

Their functions could be also combined and based on the measurement type, the information shown will be different.

Representation possibilities are the following:

**1.- "tv" key active.** Activates and deactivates the TV monitor mode, showing the image of the selected signal. In case of digital carriers, this mode will represent the first program of FTA (free to air) terrestrial multiplex and satellite transponders. If coded signal, the image will not be represented.



rev 1.2 Status bar is present for a short period of time; after it will be hidden. To makes it appear again, press **"tv"** key.

## User's Manual - mediaMAX EVO

2.- "spectrum" key active. The monitor is divided in three parts: status bar on top, spectrum and at the bottom span, level and resolution filter information.

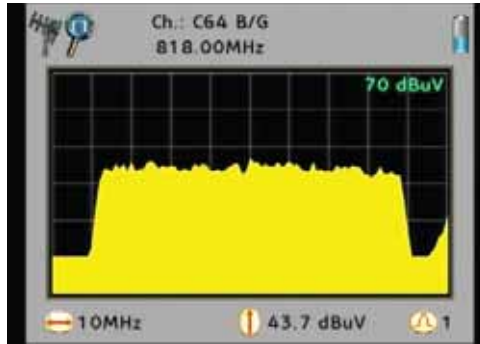

3.- "meter" key active. The monitor is divided in two parts: status bar and signal measurements information.

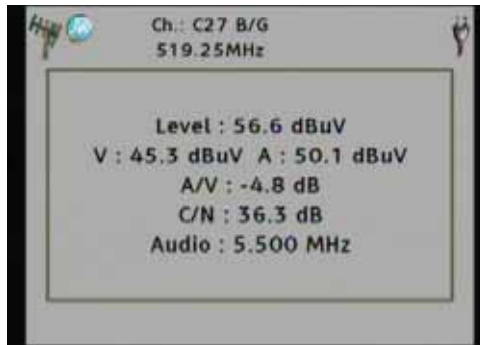

## User's Manual - mediaMAX EVO

These three options could be combined as follow:

1.- **"tv" and "spectrum"**. This two options together represents signal picture (in case of digital carriers, this mode will represent the first program of FTA (free to air) terrestrial multiplex and satellite transponders) and frequency spectrum. For analog signals, this option does not show the image.

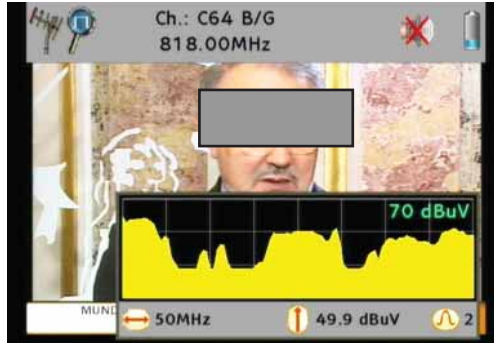

2.- **"tv" and "meter"**. These two active options represents image and measurements.

For **analog signals** the monitor is divided in four areas: status bar, syncro pulse, channel picture and graphic bar with signal level.



## User's Manual - mediaMAX EVO

With **digital signals** the monitor represents three different sections: status bar, picture of the first program of FTA (free to air) digital carriers, and one section with measurements (power, quality, BER before and after Viterbi and graphic bar with carrier power).

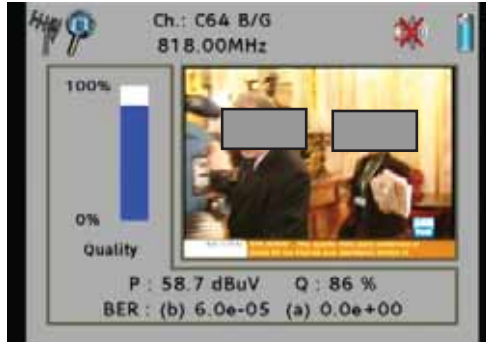

3.- **"spectrum" and "meter"**. With these two options the monitor is divided in different horizontal sections showing the status bar, channel measurement values (different if analog or digital signal), spectrum, span and current resolution filter.

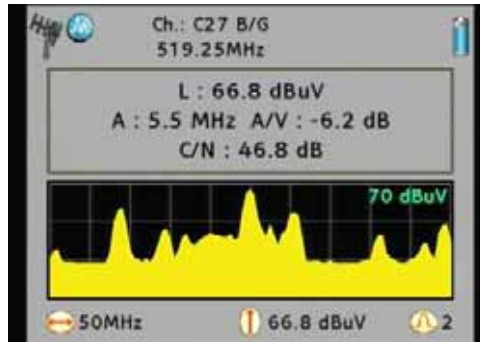

4.- **"tv", "spectrum" and "meter"**. This representation mode offers the most versatile information about the signal that has been measured. It represents on the monitor the status bar, signal image, spectrum and signal measurement information. For analog signals, this option does not show the image.

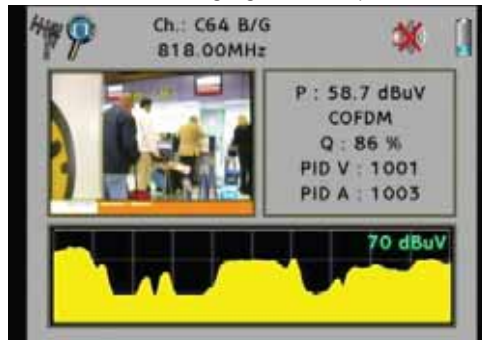

## 10.2 Satellite signal measurement

### 10.2.1 Frequency band selection

For satellite band selection, press one or several times "**band**" key until the monitor shows the message "Switching to satellite band". The switching sequence is the following:

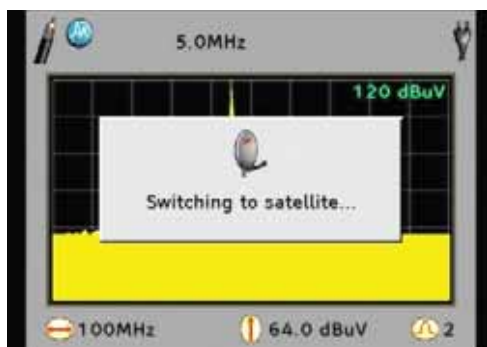
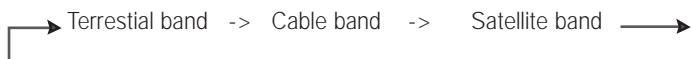

Once this option has been selected, a satellite dish appears on the left top of the status bar.

### 10.2.2 Supply LNB power

With satellite band it is important supply power to LNB in order to get the signal from the different satellite band and polarities.

- Polarity. There are two options:
  1. **Vertical:** 13 V
  2. **Horizontal:** 18 V
- Bands. There are two options:
  1. **High:** 22 KHz tone
  2. **Low:** Without tone

## User's Manual - mediaMAX EVO

To activate the LNB power supply, press through RF-IN connector, press "supply" key to open the menu.

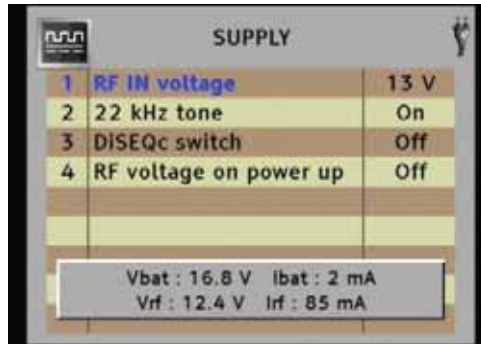

Inside the menu, select "RF IN voltage". It allows to select the following voltage options:

1. Off
2. 5V
3. 13V
4. 18V

Select the right voltage for the polarity needed and click the wheel to confirm.



In order to select the high band sending 22 KHz tone, select the option "22 KHz tone", that represents the following options:

- Off: Without tone
- On: Send 22 KHz to through RF-IN
- Auto: Send 22 KHz in automatic mode if the menu "setup>RF>satellite local oscillator" has been selected KU band or satellite band. The default value of this option is KU band.

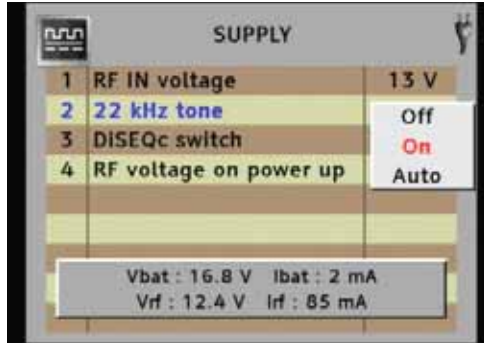

### 10.2.3 Use spectrum mode to spot a signal

To represent the frequency spectrum on the screen and spot a signal, press the "spectrum" key. When this selection is active, the green led over the key will be switched on.

In case of "tv" and "meter" keys are also switched on, the monitor shows a simultaneous representation of spectrum, picture and signal measurements. If these options are not necessary at the moment, it's possible to switch them off pressing the corresponding keys.

To identify the target signal, an easy way could be use 100MHz bandwidth span. For select it, use left and right arrow keys. The span current value is shown at the left bottom part of the monitor.

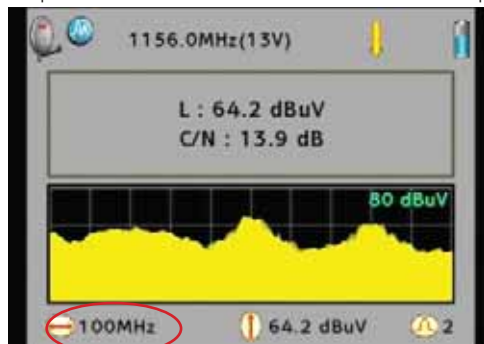

With the spectrum on screen, move the rotary wheel to sweep the frequency band to spot the target signal. If only spectrum is needed on the monitor, press the button "spectrum" to activate it. It is possible also to desactive "tv" and "meter" modes if just spectrum is necessary.

In satellite band, "nav" key selects only frequency mode to sweep the band normally by frequency with 500 KHz steps.

## 10.2.4 Measurement selection

With the target signal identified, it's necessary to select the signal type (analog or digital). Press **"options"** key, select **"Digital modulation"** and there will be two different options:

- Analog: if analog signal
- Digital: if digital signal

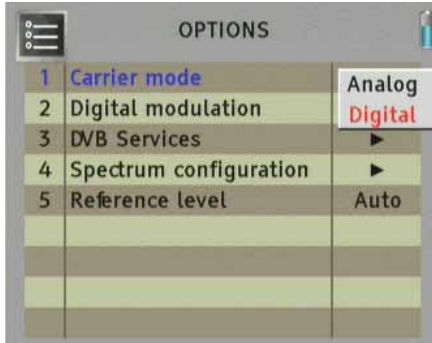

Select one of them and confirm clicking the wheel.

For digital satellite signal, it is necessary setup signal parameters. Select "Digital modulation". It is necessary to setup symbol rate and mode:

- Symbol rate: This value should be fixed based on broadcaster information
- Modo: DVB, DSS. Normally DVB will be used.
- Spectrum inversion: auto

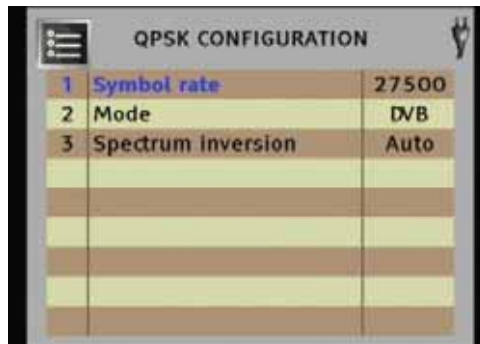

Press **"back"** key to turn back the main menu.

## 10.2.5 Make measurements

### 1.- Analog signals

To get analog satellite signal measurements, spot the signal as explained above and press “meter” key. It switches on the led over the key and the monitor and the monitor shows a screen with measures values.



If “tv” and “spectrum” are selected (the led over these keys are switched on), the monitor shows a simultaneous representation of measurements, spectrum and picture. If these two options are not necessary, is possible to cancel their representation pressing the corresponding keys.

The meter represents the following analog values:

- Level
- C/N

### 2.- Digital signals

To get digital satellite signal measurements, spot the signal as explained above and press “meter” key. It switches on the led over the key and the monitor and the monitor shows a screen with measures values.



If **"tv"** and **"spectrum"** are selected (the led over these keys are switched on), the monitor shows a simultaneous representation of measurements, spectrum and picture. If these two options are not necessary, is possible to cancel their representation pressing the corresponding keys.

The meter represents the following digital values:

- Power
- BER before Viterbi
- BER after Viterbi
- Quality (CSI)
- C/N
- MER

### 10.2.6 Picture representation

The **mediaMAX EVO** meter is equipped with three different representation modes to show the information on the screen: **"tv"**, **"spectrum"** and **"meter"**.

There is a led over these buttons that inform the user which options are being currently used. At least one of them will be always switched on.

Their functions could be also combined and based on the measurement type, the information shown will be different.

Representation possibilities are the following:

**1.- "tv" key active.** Activates and deactivates the TV monitor mode, showing the image of the selected signal. In case of digital carriers, this mode will represent the first program of FTA (free to air) terrestrial multiplex and satellite transponders. If coded signal, the image will not be represented.



Status bar is present for a short period of time; after it will be hidden. To make it appear again, press **"tv"** key.

## User's Manual - mediaMAX EVO

2.- "spectrum" key active. The monitor is divided in three parts: status bar on top, spectrum and at the bottom span, level and resolution filter information.

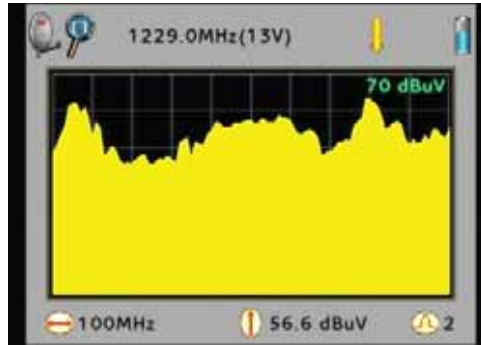

3.- "meter" key active. The monitor is divided in two parts: status bar and signal measurements information.



## User's Manual - mediaMAX EVO

These three options could be combined as follow:

1.- **"tv"** and **"spectrum"**. This two options together represents signal picture (in case of digital carriers, this mode will represent the first program of FTA (free to air) terrestrial multiplex and satellite transponders) and frequency spectrum. For analog signals this option does not show the image.



2.- **"tv"** and **"meter"**. These two active options represents image and measurements.

For **analog signals** the monitor is divided in four areas: status bar, syncro pulse, channel picture and graphic bar with signal level.

With **digital signals** the monitor represents three different sections: status bar, picture of the first program of FTA (free to air) digital carriers, and one section with measurements (power, quality, BER before and after Viterbi and graphic bar with carrier power).

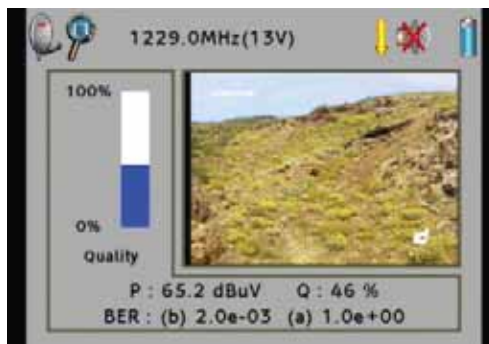

## User's Manual - mediaMAX EVO

3.- **"spectrum"** and **"meter"**. With these two options the monitor is divided in different horizontal sections showing the status bar, channel measurement values (different if analog or digital signal), spectrum, span and current resolution filter.

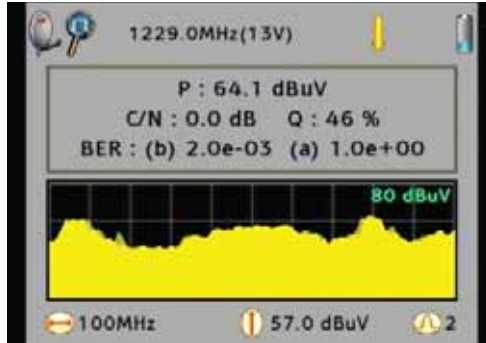

4.- **"tv"**, **"spectrum"** and **"meter"**. This representation mode offers the most versatile information about the signal that has been measured. It represents on the monitor the status bar, signal image, spectrum and signal measurement information. For analog signals this option does not show the image.

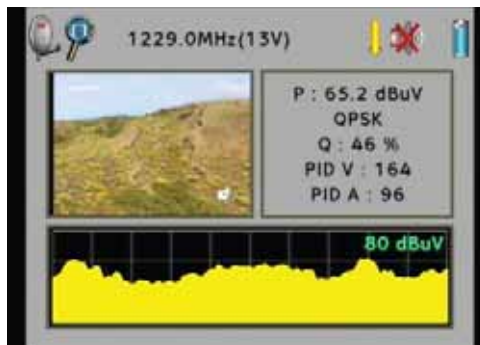

## 10.2.7 DiSEqC switch

When DiSEqC satellite switches are installed, it's necessary to use commands according this standard to get the signal from satellite LNB.

If the meter detects that the cable has been disconnected and connected again, resend the DiSEqC information to select the correct switch.

The **mediaMAX EVO** is equipped with an option inside the menu "supply" that allow to send these commands.

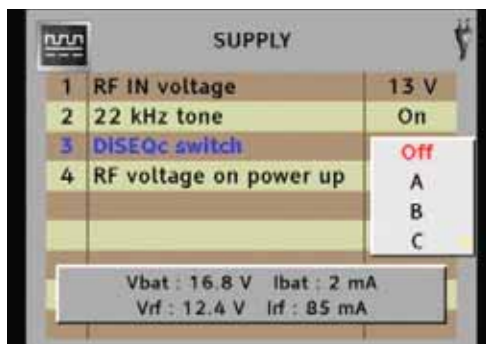

Press "supply" key and select "DiSEqC switch" option. It will show the following options:

- Off: No active
- A: Select switch A
- B: Select switch B
- C: Select switch C
- D: Select switch D

## 10.3 CABLE SIGNAL MEASUREMENTS

### 10.3.1 Frequency band selection

For cable band selection, press one or several times **"band"** key until the monitor shows the message **"Switching to satellite band"**. The switching sequence is the following:

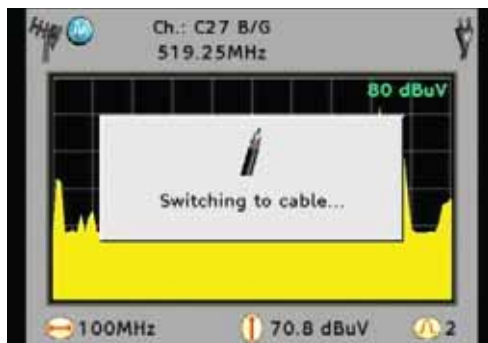
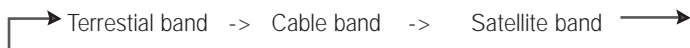

Once this option has been selected, a cable logo appears on the left top of the status bar.

In case of the meter doesn't show the above message, it could be necessary to go into the **"setup"** menu, select **"RF"** option and active **"show cable band"**.

### 10.3.2 Use spectrum mode to spot a signal

To represent the frequency spectrum on the screen and spot a signal, press the **"spectrum"** key. When this selection is active, the green led over the key will be switched on.

In case of **"tv"** and **"meter"** keys are also switched on, the monitor shows a simultaneous representation of spectrum, picture and signal measurements. If these options are not necessary at the moment, it's possible to switch them off pressing the corresponding keys.

To identify a signal, to do it with a span of 50 MHz is advised (default value in cable). For select it, use left and right arrows keys. The span current value is shown at the left bottom part of the monitor.

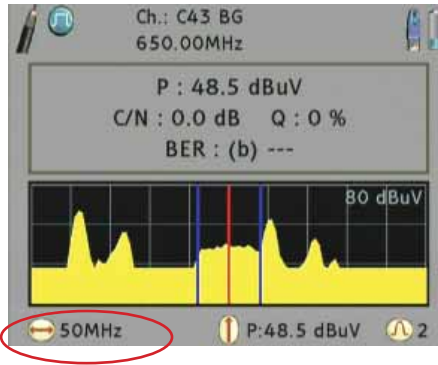

With the spectrum on screen, move the rotary wheel to sweep the frequency band to spot the target signal. If only spectrum is needed on the monitor, press the button **“spectrum”** to active it. It is possible also to desactive **“tv”** and **“meter”** modes if just spectrum is necessary.

In cable band, **“nav”** key selects only frequency mode to sweep the band normally by frequency with 100 KHz steps.

### 10.3.3 MEASUREMENT SELECTION

With the target signal identified, it's necessary to select the signal type (analog or digital). Press **“options”** key, select **“Carrier mode”** and there will be two different options:

- Analog: if analog signal
- Digital: if digital signal

Select one of them and confirm clicking the wheel.

For digital cable signal, it is necessary setup signal parameters. Select **“Digital modulation”**. It is necessary to setup the following parameters:

1. **Symbol rate:** This parameter should be fixed according to the Bit Rate (symbol rate) of the channel, data which is supplied by the operator.

**2. Spectrum inversion:** Pushing on this field, you can see the following options:

- Auto: Enables the automatic way of spectrum inversion.
- On: Enables the manual way of spectrum inversion.
- Off: Disables the manual spectrum inversion.

You should enabled in case it is necessary to invert the spectrum. If you select incorrectly the inversion of the spectrum, the reception will be not correct.

**3. Constellation:** This parameter will be fixed according to the modulation of the channel. This data is supplied by the operator of the channel. You can select different constellations (modulations): 16-QAM, 32-QAM, 64-QAM, 128-QAM y 256-QAM.

QAM CONFIGURATION		
1	Symbol rate	6875
2	Spectrum inversion	Auto
3	Constellation	32
4	Constellation display	Off

**4. Show the Constellation:** In this option you can choose the type of displaying of the constellation. Pushing on the field "Constellation Display" you can select:

- **Off:** Disables the viewing of the constellation.
- **Full:** Allows watching the 4 parts of the diagram (4 quadrants).
- **1:** Allows watching the first quadrant (higher – left).
- **2:** Allows watching the second quadrant (higher – right).
- **3:** Allows watching the third quadrant (lower – right).
- **4:** Allows watching the forth quadrant (lower – left).

Once selected the quadrant to be represented, exit of the menu, and select the "meter" mode to be able to see the constellation on the TFT monitor.



## 10.3.4 Make measurements

### 1.- Analog signals

To get analog cable signal measurements, spot the signal as explained above and press "meter" key. It switches on the led over the key and the monitor and the monitor shows a screen with measures values.

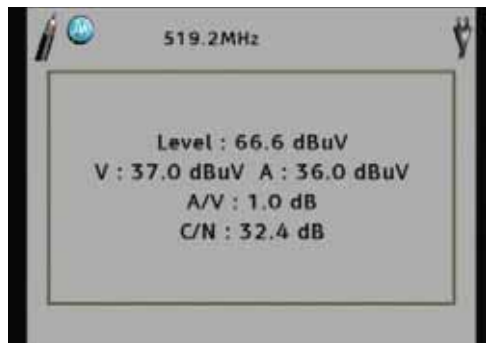

If "tv" and "spectrum" are selected (the led over these keys are switched on), the monitor shows a simultaneous representation of measurements, spectrum and picture. If these two options are not necessary, is possible to cancel their representation pressing the corresponding keys.

The meter represents the following analog values:

- Level
- Audio
- Video / audio difference
- C/N

### 2.- Digital signals

To get digital cable signal measurements, spot the signal as explained above and press "meter" key. It switches on the led over the key and the monitor and the monitor shows a screen with measures values.



If **"tv"** and **"spectrum"** are selected (the led over these keys are switched on), the monitor shows a simultaneous representation of measurements, spectrum and picture. If these two options are not necessary, is possible to cancel their representation pressing the corresponding keys.

The meter represents the following digital values:

- Power
- BER before Viterbi
- Quality (CSI)
- C/N
- MER

### 10.3.5 Picture representation

The **mediaMAX EVO** meter is equipped with three different representation modes to show the information on the screen: **"tv"**, **"spectrum"** and **"meter"**.

There is a led over these buttons that inform the user which options are being currently used. At least one of them will be always switched on.

Their functions could be also combined and based on the measurement type, the information shown will be different.

Representation possibilities are the following:

**1.- "tv" key active.** Activates and deactivates the TV monitor mode, showing the image of the selected signal. In case of digital carriers, this mode will represent the first program of FTA (free to air) terrestrial multiplex and satellite transponders. If coded signal, the image will not be represented.



Status bar is present for a short period of time; after it will be hidden. To make it appear again, press **"tv"** key.

## User's Manual - mediaMAX EVO

2.- "spectrum" key active. The monitor is divided in three parts: status bar on top, spectrum and at the bottom span, level and resolution filter information.

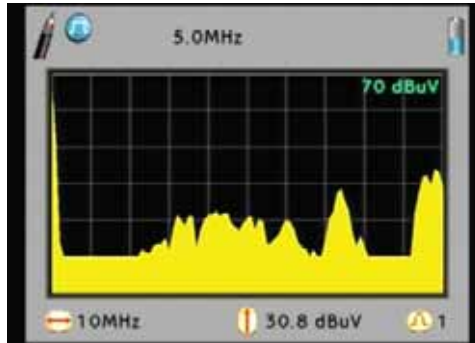

3.- "meter" key active. The monitor is divided in two parts: status bar and signal measurements information.

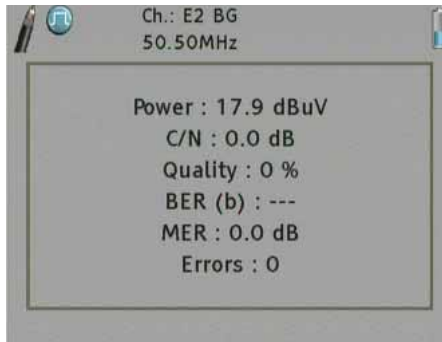

## User's Manual - mediaMAX EVO

These three options could be combined as follow:

1.- **"tv" and "spectrum"**. This two options together represents signal picture (in case of digital carriers, this mode will represent the first program of FTA - free to air) and frequency spectrum. For analog signals this option does not show the image.

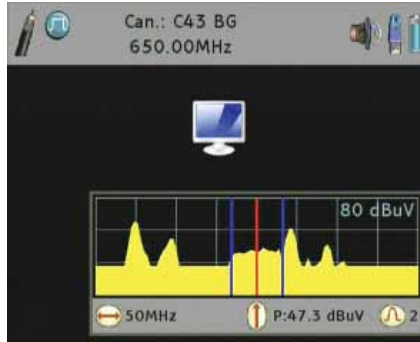

2.- **"tv" and "meter"**. These two active options represents image and measurements.

For analog signals the monitor is divided in four areas: status bar, syncro pulse, channel picture and graphic bar with signal level.

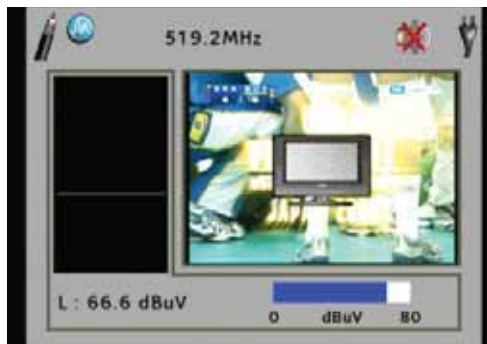

With digital signals the monitor represents three different sections: status bar, picture of the first program of FTA (free to air) digital carriers, and one section with measurements (power, quality, BER before Viterbi and graphic bar with carrier power.



3.- "spectrum" and "meter". With these two options selected the monitor is divided in different horizontal sections showing the status bar, channel measurement values (different if analog or digital signal), spectrum, span and current resolution filter.

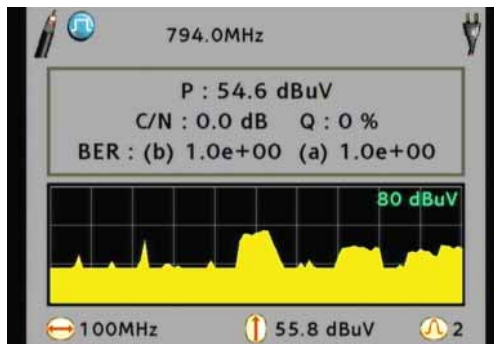

4.- "tv", "spectrum" and "meter". This representation mode offers the most versatile information about the signal that has been measured. It represents on the monitor the status bar, signal image, spectrum and signal measurement information. For analog signals this option does not show the image.

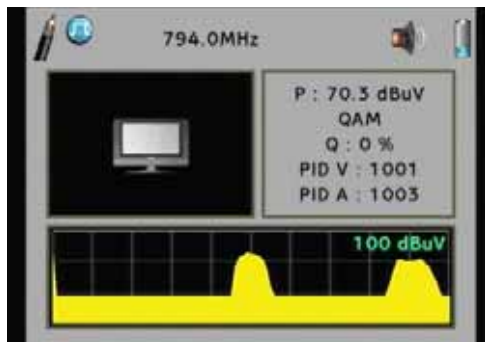

## 10.4 FM SIGNAL

### 10.4.1 Frequency band selection

In order to select FM frequencies, it's important to follow the following steps:

1. Press **"band"** key to select terrestrial band. It will show terrestrial antenna logo on left top.
2. Press **"option"** key, select **"Carrier mode"** and **"Analog"**.
3. Select audio menu pressing **"sound"** key and select **"carrier frequency"** and **"FM"**. Press click wheel or **"enter"** key to confirm.

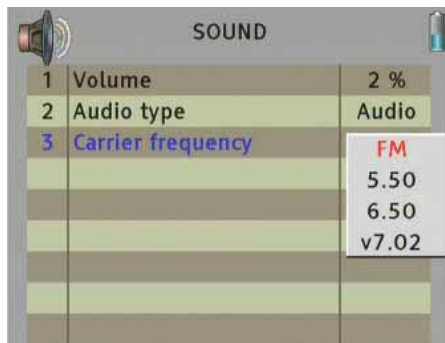

**Note:** In order to hear again analog TV audio, select **"5.50"** value in previous menu.

Select **"tv"** mode, unselecting **"meter"** and **"spectrum"** modes.



Press **"nav"** key to select frequency mode. If this mode is selected, the status bar will show the value in MHz. If channel mode is selected, it will be shown on status bar through a channel value (i.e CH: 32 B/G).

Select FM frequency in 87,5 MHz - 108 MHz band. If signal is connected, radio channel will be listened.

### 10.4.2 Signal measurement

To make a FM signal measurement, press **"meter"** key once FM mode has been selected. In the bottom of the screen it will be shown the signal measurement.



To show spectrum on screen, press **"spectrum"** key. It's recommended to use a span value of 10 MHz to have a clear graphic information of different signals.

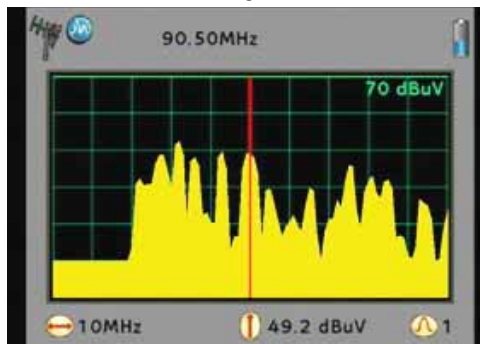

**Important:** if spectrum mode or meter mode are selected, FM audio will not be active.

## 11 PROGRAMS

**mediaMAX EVO** meter allows to create programs of the different signals that user is analyzing and measuring.

One program will store several information as current meter status, frequency, screen mode, spectrum, measurement, image, selected signal mode and supply mode if exists.

In order to select program as navigation mode, it's important that at least one program it's created before.

### 11.1 Edit programs

To create a program **mediaMAX EVO** meter, select program menu by pressing "**programs**" key. Possible options are hereafter explained:

#### 11.1.1 Create program

This option will allow to create a new program.

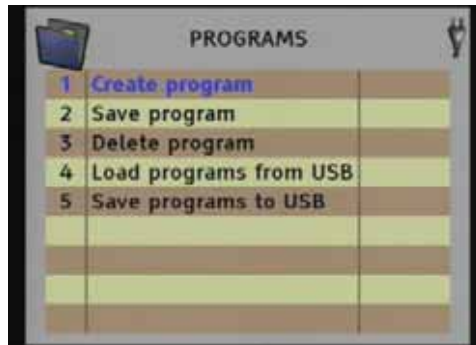

## User's Manual - mediaMAX EVO

Once this option has been selected, a new OSD window will open with "Create new program" and in blue color the text "Enter name". Press click wheel or enter key to begin the edition.



If analog signal is selected, the name of the program should be completely written. To enter letters and numbers, press "abc/123" key for alphanumerics. It's possible to delete wrong letters using left arrow key.



## User's Manual - mediaMAX EVO

If selected signal is digital, the meter will propose the name of the program based on first current program of digital transponder/multiplex. Anyhow, it's possible to change it using left arrow key.

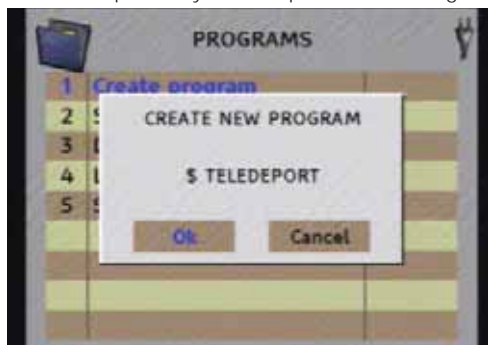

ENGLISH

### 11.1.2 Save a program

Selecting this option, the program will be stored. The option does not allow to save modifications on stored programs.

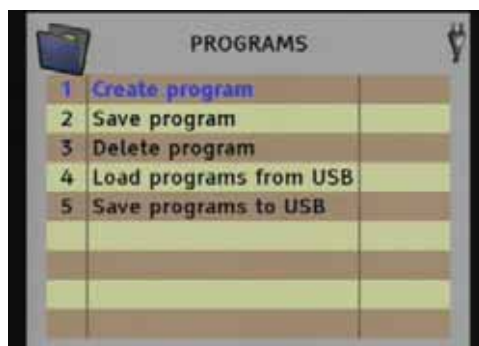

## 11.1.3 Delete a program

This option allow to delete a stored program. To do it, select the option “Delete program” and confirm with “yes” option.



This option will show a program list alphabetically sorted. Select the program and confirm the action.



## 11.1.4 Load program from USB

This option allows to upload a program from USB device. Before use this option, connect USB device. Otherwise meter will show a message asking for it.

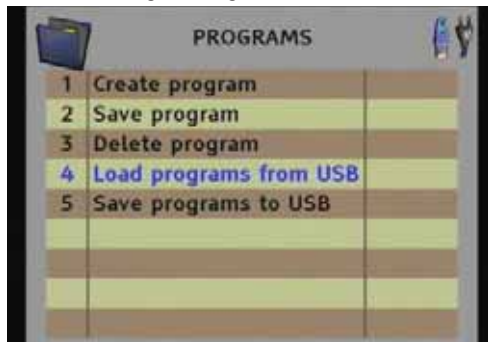

## 11.1.5 Save program to USB

This option allow to create a security copy of programs on USB device.

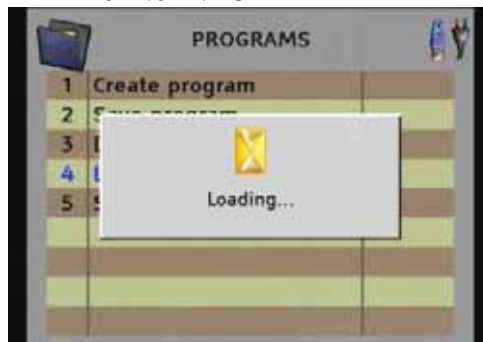

Before to use this option, connect the USB device. Otherwise the meter will show a message asking for it.

## 11.1.6 Navigation by program

If program option is selected in navigation mode, it's possible to sweep the band by program instead of frequency or channel.

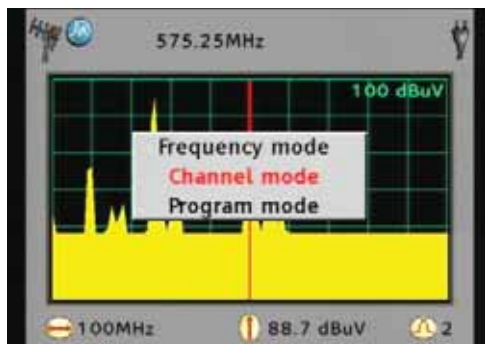

To navigate through different programs, use the click wheel. It's possible to select directly the program by pressing the "abc/123" key. This option shows the complete current program list.

## 12 KEY "FAV" FUNCTIONS

The key "fav" on the main keypad could be configured by the installer in order to select the most frequently used option. In this way, the user could be able to program this key and simplify the quick access to one function among the possible ones.

### 12.1 Configuration

To setup this key, press the "setup" key and select "system" option on the menu. In this window, select "fav key setup" and this selection will open another window showing the different options that can be assigned to this key.



Once the desired option has been selected, press "enter" to confirm.

### 13. AUTOSCAN FUNCTION

This functionality allows tuning the selected carrier automatically, it is, it scans automatically the carrier.

- When a Digital Carrier is detected, automatically it will select the correct parameters for tuning and measuring (as for Terrestrial as well as for Satellite).
- When an Analogue Carrier is detected, it automatically selects the correct modulation standard and the channel will be shown as "TV" mode.

To execute this functionality it is recommended to place the meter in "spectrum" mode, in order to be able to watch the different carriers.

Navigate through the different carriers using the navigation key, or introducing directly the frequency. Once you are placed on the analogue signal carrier or at the centre of the digital channel, please push the blue key "autoscan". At that moment the meter will test different configurations up to being able to tune correctly the scanned channel.



## 14. DATALOGGER

The Data Logger or data acquire program will allow you to convert your Field Strength Meter MediaMAX EVO in a powerful system to acquire, store and processing data.

Data Logger allows the creation of groups which contain the programs (signals to measure) as well as the measures related to these programs. It also allows the viewing of the measurements (in the same Meter) and exporting the measurements, to be able to read them later, through the Data Logger software in the Computer.

### Data Structure in the Field Meter:

The base structure of the Data Logger is the Group of Measures. It will contain the programs which will be used to carry the measures out as well as the stored measures.

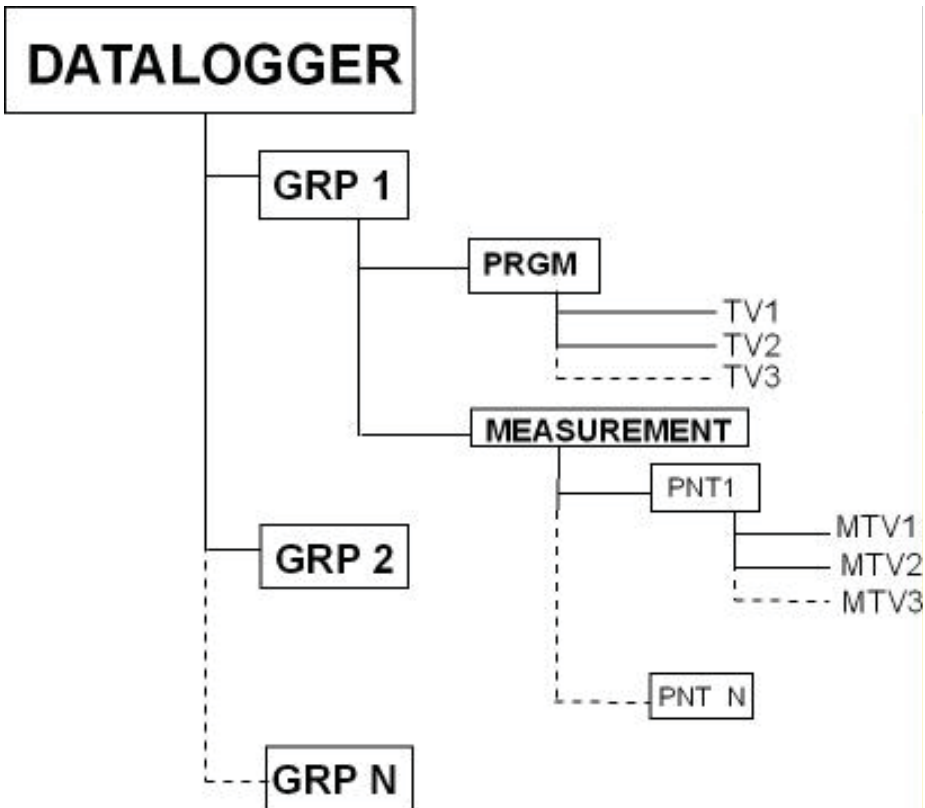

To use the data logger it is needed previously to create the programs (see point 11.1). Once the programs are created, we will group them to begin to use the data logger.

To access to Data Logger, push the "tools" button, and then go to "Data Logger" option.



The data logger disposes of the following options:

## 14.1. NEW MEASUREMENT

This option allows carrying out the measurements of a concrete group.

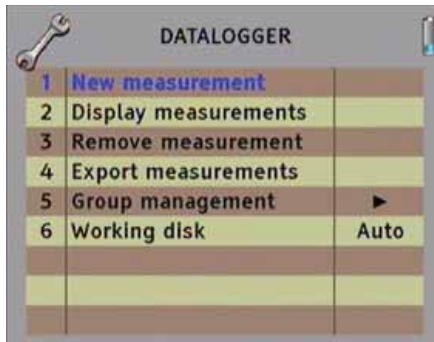

Once it is selected, a dialog box will appear with the text "New measurement". In the field "Add measurement to the group" select the name of the group where you want to store the measurement.

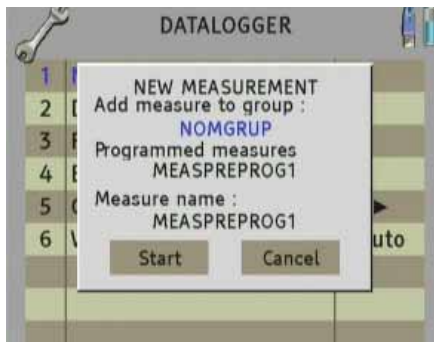

## User's Manual - mediaMAX EVO

A pre-programmed measurement point is exactly the same to a point of measurement, but it doesn't have any measurement. The advantage is that you will have the name of the measurement point without the need of introducing it into the meter. For creating these pre-programmed measurement points, it is recommended the complete version of Datalogger, which allows creating groups, programs and measurements as well as creating reports.

Push on the blue text of the field "Pre-Programmed measures" and the list for selecting the name of the folder where the measurement configurations will be stored will appear. (Only in case of creating the folder into the USB in the before specified route).

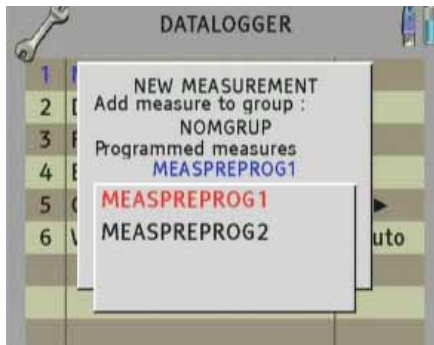

Push "enter" for selecting the name of the folder where all the measurement configurations will be stored.

Note: The field "Pre-programmed measures" can be deleted if you do not want to store the measurements into the USB device. In this case the new measurement will be edited in the field "Name of measure" directly.

Finally select the name of the measurement to carry out in the field "Name of measurement". Push on the blue text to edit the name and push "enter".

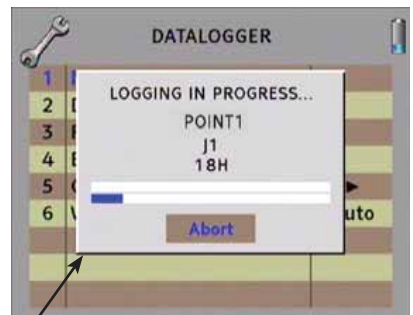
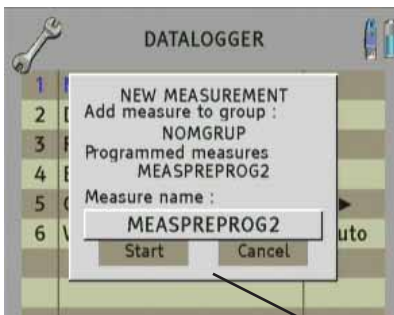

Push "Start" to begin with the measurements.

A dialog box will be opened, where you will be able to see the progress of the different programmed measurements that are part of the group. These measurements are stored in the file named previously.

When the measurements are finished, the window of measurements is automatically displayed. In case you change the band, the icon of the band is changed, if you programme to make the pauses between bands or to pause passing to FM.

## 14.2. WATCHING THE MEASURES

This option allows us to watch the measures which have been carried out with the "New measures" option.

Once selected, a dialog box will be displayed with the text "Show measure", "group" below and in blue colour the name of the group where we want to display the measure. We will also have the following fields: "Measure Point", where we will select the name with which the measurement has been stored, just in case that more than one measure has been taken with the same name. In the field "Measure" we will select the program that we want to know about and to display the measure.

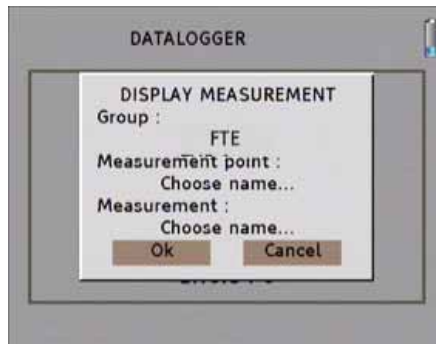

Push "Yes" to show. Pushing over the rotary key we come back to the previous menu where we can select different measures as well as show them.



rev 1.2 Turning the rotary key to right side we can move from one measure to another one without exiting to the previous menu.

## 14.3. DELETE MEASURES

This option allows deleting the file with all the measures which have been carried out in a specific group.

Once selected, a dialog box will be displayed with the text **“Delete measure”**, then **“Delete from group”** where we will introduce the name of the group where the measure has been taken, and **“Measurement Point”** where we will place the name of the file with which the measure has been stored. Finally, in the **“Measurement”** field, you should select the program where it has been measured.

ENGLISH

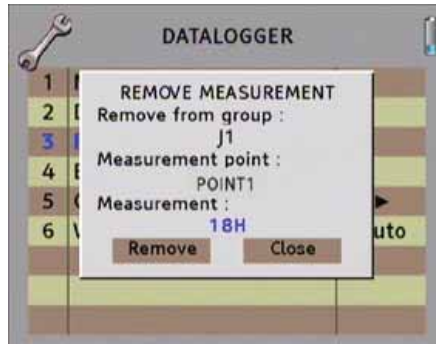

Push **“Delete”** and a confirmation dialog box will be displayed.

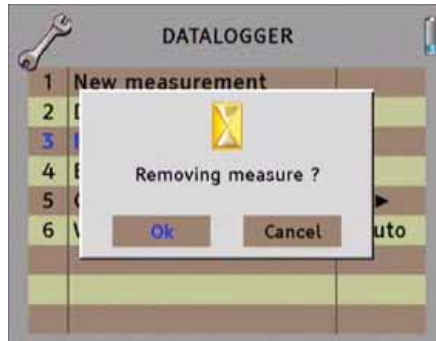

Push **“Yes”** to delete completely the measure and to continue deleting. To exit from the application, push **“Close”**.

## 14.4. EXPORT MEASURES

This option allows copying the data stored in the external USB 2.0 storage device.

Once this option has been selected, the current group data (we are working with) will be copied directly to the device.

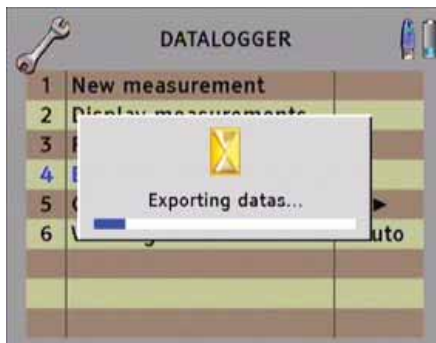

## 14.5. GROUP MANAGEMENT

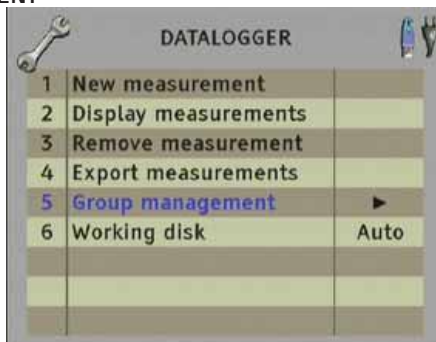

### 14.5.1. CREATING A GROUP

This option allows creating a new group.

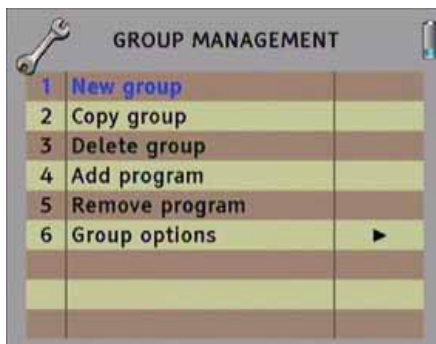

Once selected, a dialog box with the text **“Create a new group”** will be displayed, and in blue colour the text **“Write the name”**. Push the rotating key or the **“enter”** key to begin the edition.



To name the group, please introduce it with the alphanumeric keys of the keyboard. In case of error, it is possible to delete the last setter by pressing the left arrow of the horizontal cursors. Once the name has been written, please push **enter** and turn the rotating key to right to select **“Yes”** and confirm to store it.

### 14.5.2. COPY A GROUP

This option allows copying the information from one group to another one.



Once selected the option **“Copy Group”**, a dialog box is displayed with the text **“Copy from”** and in blue colour the text **“Write the name”**. Push the rotating key or the **enter** key to select the group you select to copy the information from (it only will be copied the group configuration and the contained programs. The measurements carried out in the origin group will not be copied).

Once selected, please push **enter** and turn the rotating key to right to select **“Yes”** and confirm.

## 14.5.3. DELETE A GROUP

This option allows deleting a group.



Once the option is selected, a dialog box will appear with the text **"Delete Group"** and in blue colour the text **"Select name"**. Press the rotating key or the **enter** button to select the group you want to delete.



Once the group is selected, please push **enter** button and turn the rotating key to left to select **"Yes"** and confirm to delete it. A dialog box will appear in order to confirm the deleting. Push **"Yes"**.

## 14.5.4. ADD A PROGRAM

With this option we will configure our groups with the list of programs which will compose the group.

Once the option is selected, a dialog box will appear with the text **"Add program"**. Where we can see the message **"Process Group"**, we should introduce the name of the group where we want to add a new program. Once selected, please push **"enter"**.



In the following message: **"Add program"** we will select the name of the program that we want to add to the group, which has been previously selected. (Remember that before selecting a group or program, it should be previously created).



In the dialog box there is a last option **"Watch programs of the group"**. In this mode, we can have a control about the programs that we want to add to the group. In case of duplicated programs, an error message is displayed in order to inform that the current program could not be added.



Pressing **"Add"** the program will be inserted into the group we have selected, and the dialog box will keep opened in order to continue adding new programs. To finish the application, please push **"Close"**.

### 14.5.5. DELETE A PROGRAM

This option will allow us to delete a program from a specific group.

Once the option is selected, a dialog box will appear with the text **"Delete program"**. Where we can see the message **"Process group"** we should introduce the name of the group where the program we want to delete is placed. Once it is selected, we must push **"enter"**.



In the following message: **"Delete group"**, please select the name of the program that you want to delete. Pushing the **"Delete"** button an additional dialog box will be displayed to confirm the deleting of the program.



Push **"Yes"**. To finish, please push **"Close"** button.

## 14.5.6. GROUP OPTIONS

This option allow us to configure all the following options:

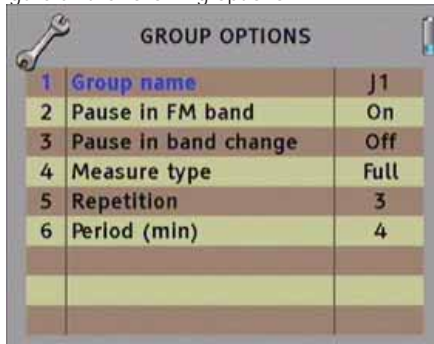

### 14.5.6.1.NAME OF THE GROUP

Once this option is selected, a dialog box will appear with the list of groups created. This option allows selecting the group we want to work with, simply pushing over it.

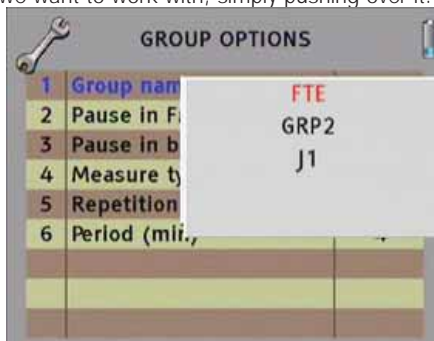

## 14.5.6.2. PAUSE IN FM BAND

This option allows changing the connector we are using for the one of the FM connection where we are carrying measures out, due to the measurement in FM in several times could be made in another connector.

Meanwhile we are making the measure of the group, if the Meter detects a FM program, it would pause the measurement and it would wait up to the confirmation again once the cable has been changed. Once the FM measure is finished and you are in a different measure, the Meter will come back to pause the measurement and wait to the confirmation to continue.



Please, push the rotating key to watch the options and to choose "On" / "Off" according to the kind of measure we are going to make.

## 14.5.6.3. PAUSE IN BAND SWITCHING

This option allows changing the connector we are using for another one from another band, as Satellite, Terrestrial, etc. The philosophy is the same as in point 14.5.6.2.

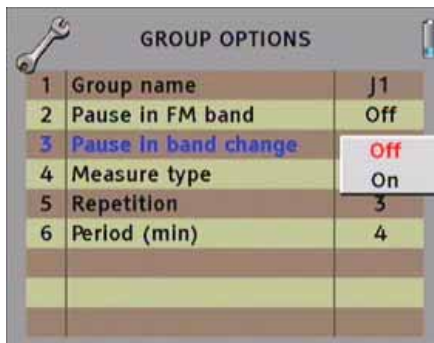

## 14.5.6.4. KIND OF MEASURE

This option allows selecting to make a complete measure or a Basic measure.

**Complete:** Depending on the memory where the measures are stored, you can find:

- If it is internal memory:
  - **Analogue measure:** you can store measures, spectrum and line of synchronism (the FM signals do not store the line of synchronism).
  - **Digital measure:** the measures and the spectrum are stored.
- If it is external USB memory:
  - It would be the same case than in the **internal memory**, but in case of TV signal, the picture would be stored as well.

**Basic:** Only the value of the measures will be stored, independently of the kind of storage memory device.



## 14.5.6.5. REPEATING

With this option we can select between 1 to 255 values, it is the number of times we want the measure is repeated in order to get more accuracy in the final calculation.

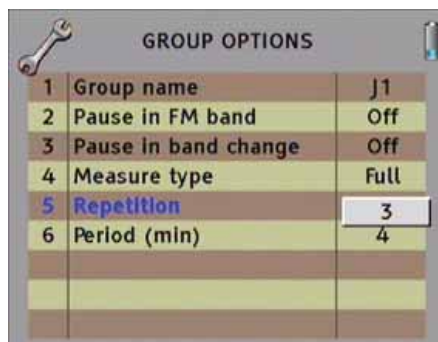

## 14.5.6.6. PERIOD

It is the repeating time of the measurement, by default one and it is expressed in minutes. Every time, the measure will be repeated. If we push on the rotating key we can write a value between 1 and 256.



## 14.5.6.7. TEMPORIZE MEASUREMENTS

This option allows configuring the time to programme a measurement at one specific time. In case this option is enabled, the option for configuring the time when the new measurement will be carried out will be displayed.

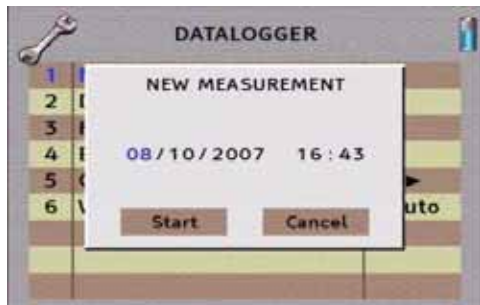

## 14.6. DISK OF WORKING

With this option we have the possibility of choosing if we want to work into the internal disk or in the external storage device USB 2.0.

Once the option is selected, a dialog box will appear and we will be able to choose among three different options.

- **Auto:** The Meter decides where the data will be stored. If there is external memory connected, the Meter will store the data in it. If not, it will use the internal memory.
- **USB:** The Meter always will try to use the external memory connected to the USB port. If this memory has not been connected an error message will be shown, reminding that there was an error storing the data and it will be not stored.
- **Internal:** Always the internal memory is used to store the data.

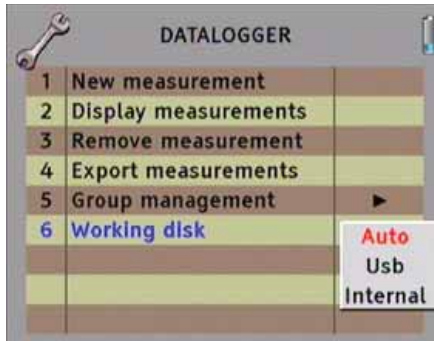

**NOTE:** If the kind of measure of a group is complete and it is selected USB as storage device, the Meter will be able to store a capture of the Picture in JPEG format to be viewed later in the Data Logger software in the computer.

## 15. SECURITY COPY

This option allows configuring the following options through the configuration menu:

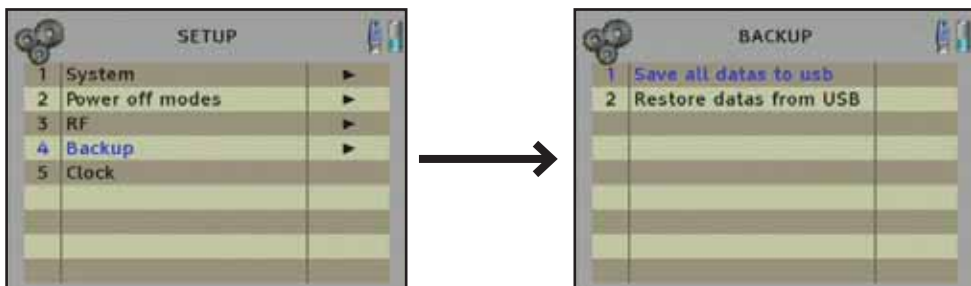

### 15.1. COPY ALL TO USB

Once this option is selected, a dialog box will appear showing the name of the file (in .zip format) with which will be stored into the USB device. The file name has the format /YEAR/MONTH/DAY/HOUR/MINUES/SECONDS.

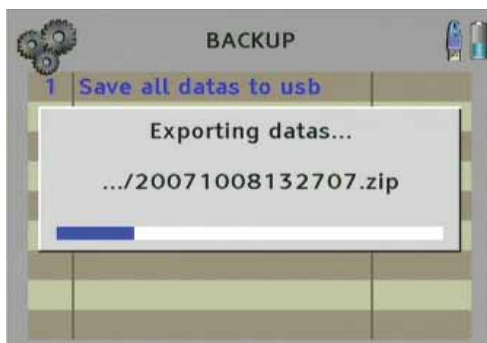

Note: if the .zip file is decompressed, the different files will be classified in different folders depending on the type of file (extension). In this manner, the security copy is organized on Programs, Datalogger, Satellites or Autoscan.

## 15.2. RESTORE COPY FROM USB

This option allows restoring the meter. There are different options for restoring that we can select through this option (All, Programs, Autoscan, Satellites, and Datalogger). The dialog box of configuration appears for selecting the name of the backup file we want to restore as well as the previous options of restoring:

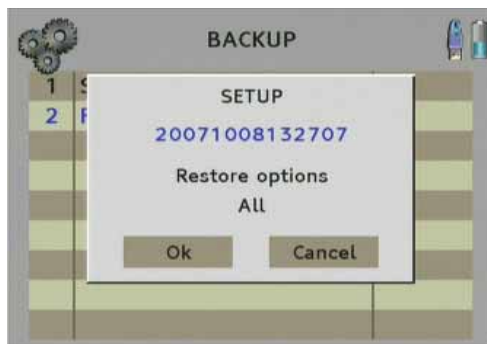

Pushing on the backup, a dialog box opens with the list of available files to be restored:



## User's Manual - mediaMAX EVO

Push on the name to select the file that you want to restore. Then push on the option "All" to see the available options that you want to restore.

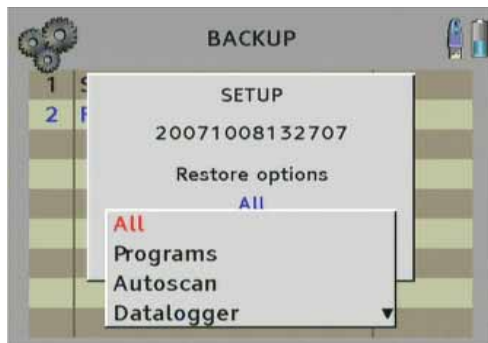

- Restore All: For overwriting all the files of the security copy.
- Restore Programs: For overwriting the list of pre-defined programs in the security copy.
- Restore Autoscan: For overwriting the Autoscan tuning configurations.
- Restore Satellites: For overwriting the list of satellites for the satellite locator.
- Restore Datalogger: For overwriting the options of Datalogger.

Push "Yes" for restoring.



## 16. SATELLITE LOCATOR

This tool allows carrying out the following actions:

- 1) Identify the satellite
- 2) Search a satellite
- 3) Configuration of options



### 16.1. IDENTIFY THE SATELLITE

This option searches based in a list of satellites that the meter has configured and it will identify the satellite that is being tuned. It informs if the satellite is or not locked.

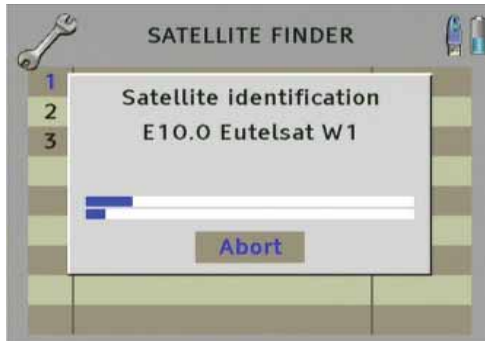

Once the satellite is identified, a message confirming that the satellite has been identified will be displayed.



## 16.2 SEARCHING A SATELLITE

This option allows searching a specific satellite placed in the list of satellites the meter has, and to know if it is locked or not. Selecting this option, the following dialog box will appear, in order to select the satellite you want to search.



Depending on if the satellite is locked or not, the following configurations will be shown, indicating: the power level, the DiSEqC switch status as well as the RF input voltage.



Not locked



Locked

## 16.3. OPTIONS

Into this menu, you can configure the following options:

- 1) Add a satellite.
- 2) Delete a satellite.
- 3) Import Satellites.
- 4) Export satellites.
- 5) Show the satellites.
- 6) New parameters Satellite



### 16.3.1 ADD A NEW SATELLITE

This option allows introducing a new satellite into the list. The following dialog box will be displayed, where a new name for the satellite must be introduced.

Note: In order to it works, the meter should be locked to a digital satellite signal previously.



Push on the blue text "Introduce name" to edit the field:

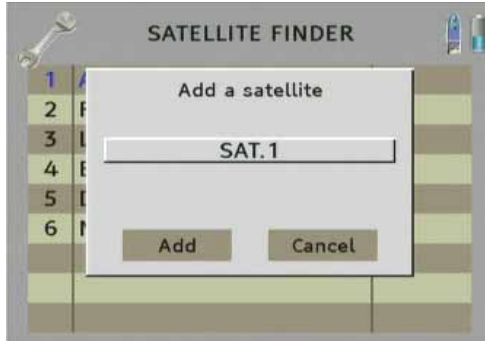

Once the field is edited, push the button "Add".

### 16.3.2. DELETE SATELLITES

This option allow deleting a satellite previously introduced into the list. Pushing on the blue text, the list of satellites will appear. Select which satellite you want to delete.

Push the "Delete" button and then the key "Yes" in the next dialog box for confirming the deleting of the satellite.

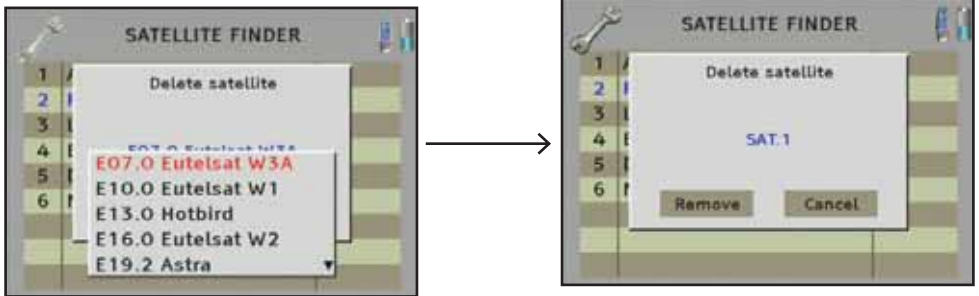

### 16.3.3. IMPORT SATELLITES

This option allows importing one satellite list from a USB device. Pushing over this option, the selected file will be loaded for importing the list of satellites from the USB device.



## 16.3.4. EXPORT SATELLITES

This option allows saving the configuration of the satellite list into a USB device. Pushing on this option, the last configuration will be saved on this file.



## 16.3.5. SHOW SATELLITES

This option allows showing the list of satellites. Pushing on the blue text, a dialog box will appear with the list of satellites.

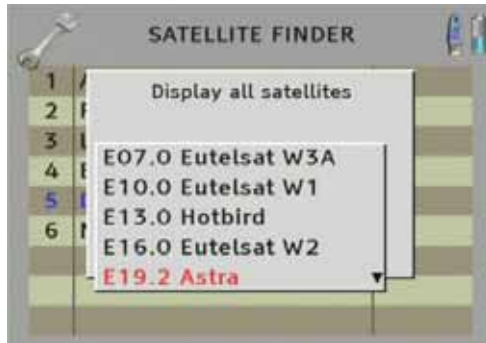

## 16.3.6. NEW PARAMETERS SATELLITE

This option allows upgrading the parameters from one specific satellite and overwriting them on the previous data.

Note: The meter must be locked to a digital satellite signal previously in order to make this option work.



Select the satellite to upgrade.

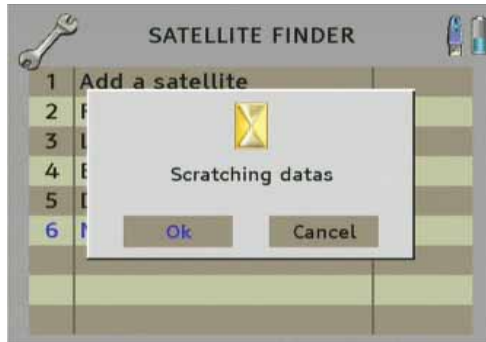

Confirm the upgrading of the data.



# ANNEX I

## VIEWER OF EVO DATA LOGGER

# User's Manual - mediaMAX EVO

## VIEWER OF EVO DATA LOGGER

The viewer of EVO Data Logger shows the measured data into the Test Equipment and it represents them in this programme.

You will be able to import the data and to store them for processing them later.

Click on the **"File"** menu and select the **"Import"** option. A dialog box named **"Search Folder"** will appear. Select then the folder **"log"** (generated by MediaMAX EVO when is exporting the data into the USB device), and choose **"OK"**.

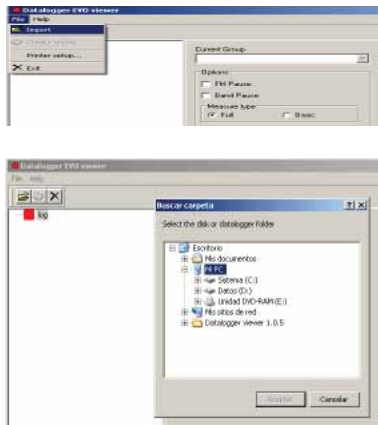

As soon as the measurement data are read from USB, they will be exported with the file structure into the Data Logger Viewer.

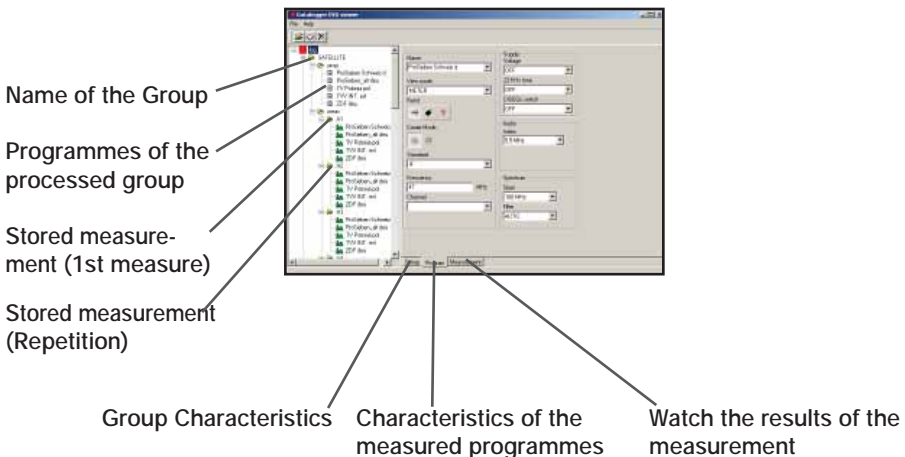

# User's Manual - mediaMAX EVO

The measured data will be able to be watched and printed out.

For printing select the book symbol button to generate the documents.

In next window you should select the option **"Group of measurement"** that you want to print out.

The field **"information of the report"** can be filled out as you prefer with the data that describe the content of the group (information that will be shown in the first page of the generated report).



After introducing all the data, confirm them with the button "Create".

In the next window select the output options.

Type of selected printer

Destination printer

Destination file

File format type

Number of copies

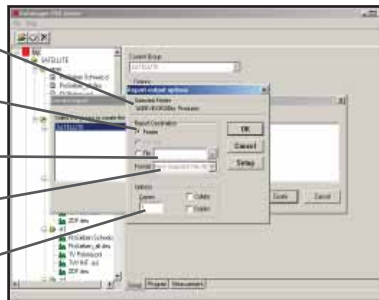

Please, confirm just pressing **OK**.

**NOTE:** In case of exporting files to PDF format, you should add to the file ".pdf" manually. For example, if the file is called "test", you should name it "test.pdf"

# ANNEX II CHANNELS PLAN

# User's Manual - mediaMAX EVO

## B/G CCIR STANDARD

CHAN.	IMAGE FREQ.	CENTER FREQ.	BAND	CHAN.	IMAGE FREQ.	CENTER FREQ.	BAND
E2	48,25	50,50	VHL	S28	359,25	362,00	VHH
E3	55,25	57,50	VHL	S29	367,25	370,00	VHH
E4	62,25	64,50	VHL	S30	375,25	378,00	VHH
				S31	383,25	386,00	VHH
S1	105,25	107,50	VHL	S32	391,25	394,00	VHH
S2	112,25	114,50	VHL	S33	399,25	402,00	VHH
S3	119,25	121,50	VHL	S34	407,25	410,00	VHH
S4	126,25	128,50	VHL	S35	415,25	418,00	VHH
S5	133,25	135,50	VHL	S36	423,25	426,00	UHF
S6	140,25	142,50	VHL	S37	431,25	434,00	UHF
S7	147,25	149,50	VHL	S38	439,25	442,00	UHF
S8	154,25	156,50	VHH	S39	447,25	450,00	UHF
S9	161,25	163,50	VHH	S40	455,25	458,00	UHF
S10	168,25	170,50	VHH	S41	463,25	466,00	UHF
E5	175,25	177,50	VHH	C21	471,25	474,00	UHF
E6	182,25	184,50	VHH	C22	479,25	482,00	UHF
E7	189,25	191,50	VHH	C23	487,25	490,00	UHF
E8	196,25	198,50	VHH	C24	495,25	498,00	UHF
E9	203,25	205,50	VHH	C25	503,25	506,00	UHF
E10	210,25	212,50	VHH	C26	511,25	514,00	UHF
E11	217,25	219,50	VHH	C27	519,25	522,00	UHF
E12	224,25	226,50	VHH	C28	527,25	530,00	UHF
				C29	535,25	538,00	UHF
S11	231,25	233,50	VHH	C30	543,25	546,00	UHF
S12	238,25	240,50	VHH	C31	551,25	554,00	UHF
S13	245,25	247,50	VHH	C32	559,25	562,00	UHF
S14	252,25	254,50	VHH	C33	567,25	570,00	UHF
S15	259,25	261,50	VHH	C34	575,25	578,00	UHF
S16	266,25	268,50	VHH	C35	583,25	586,00	UHF
S17	273,25	275,50	VHH	C36	591,25	594,00	UHF
S18	280,25	282,50	VHH	C37	599,25	602,00	UHF
S19	287,25	289,50	VHH	C38	607,25	610,00	UHF
S20	294,25	296,50	VHH	C39	615,25	618,00	UHF
S21	303,25	306,00	VHH	C40	623,25	626,00	UHF
S22	311,25	314,00	VHH	C41	631,25	634,00	UHF
S23	319,25	322,00	VHH	C42	639,25	642,00	UHF
S24	327,25	330,00	VHH	C43	647,25	650,00	UHF
S25	335,25	338,00	VHH	C44	655,25	658,00	UHF
S26	343,25	346,00	VHH	C45	663,25	666,00	UHF
S27	351,25	354,00	VHH	C46	671,25	674,00	UHF

ENGLISH

rev 1.2

## B/G CCIR STANDARD (CONTINUED)

CHAN.	IMAGE FREQ.	CENTER FREQ.	BAND
C47	679,25	682,00	UHF
C48	687,25	690,00	UHF
C49	695,25	698,00	UHF
C50	703,25	706,00	UHF
C51	711,25	714,00	UHF
C52	719,25	722,00	UHF
C53	727,25	730,00	UHF
C54	735,25	738,00	UHF
C55	743,25	746,00	UHF
C56	751,25	754,00	UHF
C57	759,25	762,00	UHF
C58	767,25	770,00	UHF
C59	775,25	778,00	UHF
C60	783,25	786,00	UHF
C61	791,25	794,00	UHF
C62	799,25	802,00	UHF
C63	807,25	810,00	UHF
C64	815,25	818,00	UHF
C65	823,25	826,00	UHF
C66	831,25	834,00	UHF
C67	839,25	842,00	UHF
C68	847,25	850,00	UHF
C69	855,25	858,00	UHF

# User's Manual - mediaMAX EVO

## L/L' STANDARD

CHAN.	IMAGE FREQ.	CENTER FREQ.	BAND	CHAN.	IMAGE FREQ.	CENTER FREQ.	BAND
5	176,00	178,75	VHH	C42	639,25	642,00	UHF
6	184,00	186,75	VHH	C43	647,25	650,00	UHF
7	192,00	194,75	VHH	C44	655,25	658,00	UHF
8	200,00	202,75	VHH	C45	663,25	666,00	UHF
9	208,00	210,75	VHH	C46	671,25	674,00	UHF
10	216,00	218,75	VHH	C47	679,25	682,00	UHF
				C48	687,25	690,00	UHF
C21	471,25	474,00	UHF	C49	695,25	698,00	UHF
C22	479,25	482,00	UHF	C50	703,25	706,00	UHF
C23	487,25	490,00	UHF	C51	711,25	714,00	UHF
C24	495,25	498,00	UHF	C52	719,25	722,00	UHF
C25	503,25	506,00	UHF	C53	727,25	730,00	UHF
C26	511,25	514,00	UHF	C54	735,25	738,00	UHF
C27	519,25	522,00	UHF	C55	743,25	746,00	UHF
C28	527,25	530,00	UHF	C56	751,25	754,00	UHF
C29	535,25	538,00	UHF	C57	759,25	762,00	UHF
C30	543,25	546,00	UHF	C58	767,25	770,00	UHF
C31	551,25	554,00	UHF	C59	775,25	778,00	UHF
C32	559,25	562,00	UHF	C60	783,25	786,00	UHF
C33	567,25	570,00	UHF	C61	791,25	794,00	UHF
C34	575,25	578,00	UHF	C62	799,25	802,00	UHF
C35	583,25	586,00	UHF	C63	807,25	810,00	UHF
C36	591,25	594,00	UHF	C64	815,25	818,00	UHF
C37	599,25	602,00	UHF	C65	823,25	826,00	UHF
C38	607,25	610,00	UHF	C66	831,25	834,00	UHF
C39	615,25	618,00	UHF	C67	839,25	842,00	UHF
C40	623,25	626,00	UHF	C68	847,25	850,00	UHF
C41	631,25	634,00	UHF	C69	855,25	858,00	UHF

# User's Manual - mediaMAX EVO

## D/K/K'/DK PAL STANDARD

CHAN.	IMAGE FREQ.	CENTER FREQ.	BAND	CHAN.	IMAGE FREQ.	CENTER FREQ.	BAND
R1	49,75	52,50	VHL	C38	607,25	610,00	UHF
R2	59,25	62,00	VHL	C39	615,25	618,00	UHF
R3	77,25	80,00	VHL	C40	623,25	626,00	UHF
				C41	631,25	634,00	UHF
R4	85,25	88,00	VHL	C42	639,25	642,00	UHF
R5	93,25	96,00	VHL	C43	647,25	650,00	UHF
				C44	655,25	658,00	UHF
R6	175,25	178,00	VHH	C45	663,25	666,00	UHF
R7	183,25	186,00	VHH	C46	671,25	674,00	UHF
R8	191,25	194,00	VHH	C47	679,25	682,00	UHF
R9	199,25	202,00	VHH	C48	687,25	690,00	UHF
R10	207,25	210,00	VHH	C49	695,25	698,00	UHF
R11	215,25	218,00	VHH	C50	703,25	706,00	UHF
R12	223,25	226,00	VHH	C51	711,25	714,00	UHF
				C52	719,25	722,00	UHF
C21	471,25	474,00	UHF	C53	727,25	730,00	UHF
C22	479,25	482,00	UHF	C54	735,25	738,00	UHF
C23	487,25	490,00	UHF	C55	743,25	746,00	UHF
C24	495,25	498,00	UHF	C56	751,25	754,00	UHF
C25	503,25	506,00	UHF	C57	759,25	762,00	UHF
C26	511,25	514,00	UHF	C58	767,25	770,00	UHF
C27	519,25	522,00	UHF	C59	775,25	778,00	UHF
C28	527,25	530,00	UHF	C60	783,25	786,00	UHF
C29	535,25	538,00	UHF	C61	791,25	794,00	UHF
C30	543,25	546,00	UHF	C62	799,25	802,00	UHF
C31	551,25	554,00	UHF	C63	807,25	810,00	UHF
C32	559,25	562,00	UHF	C64	815,25	818,00	UHF
C33	567,25	570,00	UHF	C65	823,25	826,00	UHF
C34	575,25	578,00	UHF	C66	831,25	834,00	UHF
C35	583,25	586,00	UHF	C67	839,25	842,00	UHF
C36	591,25	594,00	UHF	C68	847,25	850,00	UHF
C37	599,25	602,00	UHF	C69	855,25	858,00	UHF

# User's Manual - mediaMAX EVO

## I STANDARD

CHAN.	IMAGE FREQ.	CENTER FREQ.	BAND	CHAN.	IMAGE FREQ.	CENTER FREQ.	BAND
IA	48,75	51,50	VHL	C40	623,25	626,00	UHF
IB	56,75	59,50	VHL	C41	631,25	634,00	UHF
IC	64,75	67,50	VHL	C42	639,25	642,00	UHF
				C43	647,25	650,00	UHF
ID	175,25	178,00	VHH	C44	655,25	658,00	UHF
IE	183,25	186,00	VHH	C45	663,25	666,00	UHF
IF	191,25	194,00	VHH	C46	671,25	674,00	UHF
IG	199,25	202,00	VHH	C47	679,25	682,00	UHF
IH	207,25	210,00	VHH	C48	687,25	690,00	UHF
IJ	215,25	218,00	VHH	C49	695,25	698,00	UHF
				C50	703,25	706,00	UHF
C21	471,25	474,00	UHF	C51	711,25	714,00	UHF
C22	479,25	482,00	UHF	C52	719,25	722,00	UHF
C23	487,25	490,00	UHF	C53	727,25	730,00	UHF
C24	495,25	498,00	UHF	C54	735,25	738,00	UHF
C25	503,25	506,00	UHF	C55	743,25	746,00	UHF
C26	511,25	514,00	UHF	C56	751,25	754,00	UHF
C27	519,25	522,00	UHF	C57	759,25	762,00	UHF
C28	527,25	530,00	UHF	C58	767,25	770,00	UHF
C29	535,25	538,00	UHF	C59	775,25	778,00	UHF
C30	543,25	546,00	UHF	C60	783,25	786,00	UHF
C31	551,25	554,00	UHF	C61	791,25	794,00	UHF
C32	559,25	562,00	UHF	C62	799,25	802,00	UHF
C33	567,25	570,00	UHF	C63	807,25	810,00	UHF
C34	575,25	578,00	UHF	C64	815,25	818,00	UHF
C35	583,25	586,00	UHF	C65	823,25	826,00	UHF
C36	591,25	594,00	UHF	C66	831,25	834,00	UHF
C37	599,25	602,00	UHF	C67	839,25	842,00	UHF
C38	607,25	610,00	UHF	C68	847,25	850,00	UHF
C39	615,25	618,00	UHF	C69	855,25	858,00	UHF

# User's Manual - mediaMAX EVO

## M/N STANDARD

CHAN.	IMAGE FREQ.	CENTER FREQ.	BAND	CHAN.	IMAGE FREQ.	CENTER FREQ.	BAND
A2	55,25	57,00	VHL	C42	639,25	641,00	UHF
A3	61,25	63,00	VHL	C43	645,25	647,00	UHF
A4	67,25	69,00	VHL	C44	651,25	653,00	UHF
				C45	657,25	659,00	UHF
A5	77,25	79,00	VHL	C46	663,25	665,00	UHF
A6	83,25	85,00	VHL	C47	669,25	671,00	UHF
				C48	675,25	677,00	UHF
A7	175,25	177,00	VHH	C49	681,25	683,00	UHF
A8	181,25	183,00	VHH	C50	687,25	689,00	UHF
A9	187,25	189,00	VHH	C51	693,25	695,00	UHF
A10	193,25	195,00	VHH	C52	699,25	701,00	UHF
A11	199,25	201,00	VHH	C53	705,25	707,00	UHF
A12	205,25	207,00	VHH	C54	711,25	713,00	UHF
A13	211,25	213,00	VHH	C55	717,25	719,00	UHF
C14	471,25	473,00	UHF	C56	723,25	725,00	UHF
C15	477,25	479,00	UHF	C57	729,25	731,00	UHF
C16	483,25	485,00	UHF	C58	735,25	737,00	UHF
C17	489,25	491,00	UHF	C59	741,25	743,00	UHF
C18	495,25	497,00	UHF	C60	747,25	749,00	UHF
C19	501,25	503,00	UHF	C61	753,25	755,00	UHF
C20	507,25	509,00	UHF	C62	759,25	761,00	UHF
C21	513,25	515,00	UHF	C63	765,25	767,00	UHF
C22	519,25	521,00	UHF	C64	771,25	773,00	UHF
C23	525,25	527,00	UHF	C65	777,25	779,00	UHF
C24	531,25	533,00	UHF	C66	783,25	785,00	UHF
C25	537,25	539,00	UHF	C67	789,25	791,00	UHF
C26	543,25	545,00	UHF	C68	795,25	797,00	UHF
C27	549,25	551,00	UHF	C69	801,25	803,00	UHF
C28	555,25	557,00	UHF	C70	807,25	809,00	UHF
C29	561,25	563,00	UHF	C71	813,25	815,00	UHF
C30	567,25	569,00	UHF	C72	819,25	821,00	UHF
C31	573,25	575,00	UHF	C73	825,25	827,00	UHF
C32	579,25	581,00	UHF	C74	831,25	833,00	UHF
C33	585,25	587,00	UHF	C75	837,25	839,00	UHF
C34	591,25	593,00	UHF	C76	843,25	845,00	UHF
C35	597,25	599,00	UHF	C77	849,25	851,00	UHF
C36	603,25	605,00	UHF	C78	855,25	857,00	UHF
C37	609,25	611,00	UHF	C79	861,25	863,00	UHF
C38	615,25	617,00	UHF	C80	867,25	869,00	UHF
C39	621,25	623,00	UHF	C81	873,25	875,00	UHF
C40	627,25	629,00	UHF	C82	879,25	881,00	UHF
C41	633,25	635,00	UHF	C83	885,25	887,00	UHF

# User's Manual - mediaMAX EVO

## B/B AUSTRALIA STANDARD

CHAN.	IMAGE FREQ.	CENTER FREQ.	BAND	CHAN.	IMAGE FREQ.	CENTER FREQ.	BAND
0	46,25	48,50	VHL	S22	310,25	312,50	VHH
1	57,25	59,50	VHL	S23	317,25	319,50	VHH
2	64,25	66,50	VHL	S24	324,25	326,50	VHH
3	86,25	88,50	VHL	S25	331,25	333,50	VHH
4	95,25	97,50	VHL	S26	338,25	340,50	VHH
5	102,25	104,50	VHL	S27	345,25	347,50	VHH
				S28	352,25	354,50	VHH
S1	105,25	107,50	VHL	S29	359,25	361,50	VHH
S2	112,25	114,50	VHL	S30	366,25	368,50	VHH
S3	119,25	121,50	VHL	S31	373,25	375,50	VHH
S4	126,25	128,50	VHL	S32	380,25	382,50	VHH
S5	133,25	135,50	VHL	S33	387,25	389,50	VHH
				S34	394,25	396,50	VHH
5A	138,25	140,50	VHL	S35	401,25	401,50	VHH
				S36	408,25	410,50	VHH
S6	140,25	142,50	VHL	S37	415,25	417,50	VHH
S7	147,25	149,50	VHL	S38	422,25	424,50	UHF
S8	154,25	156,50	VHH	S39	429,25	431,50	UHF
S9	161,25	163,50	VHH	S40	436,25	438,50	UHF
S10	168,25	170,50	VHH	S41	443,25	445,50	UHF
6	175,25	177,50	VHH	20	471,25	473,50	UHF
7	182,25	184,50	VHH	21	478,25	480,50	UHF
8	189,25	191,50	VHH	22	485,25	487,50	UHF
9	196,25	198,50	VHH	23	492,25	494,50	UHF
9A	203,25	205,50	VHH	24	499,25	501,50	UHF
10	209,25	211,50	VHH	25	506,25	508,50	UHF
10N	210,25	212,50	VHH	26	513,25	515,50	UHF
11	216,25	218,50	VHH	27	520,25	522,50	UHF
11N	217,25	219,50	VHH	28	527,25	529,50	UHF
12	224,25	226,50	VHH	29	534,25	536,50	UHF
				30	541,25	543,50	UHF
S11	231,25	233,50	VHH	31	548,25	550,50	UHF
S12	238,25	240,50	VHH	32	555,25	557,50	UHF
S13	245,25	247,50	VHH	33	562,25	564,50	UHF
S14	252,25	254,50	VHH	34	569,25	571,50	UHF
S15	259,25	261,50	VHH	35	576,25	578,50	UHF
S16	266,25	268,50	VHH	36	583,25	585,50	UHF
S17	273,25	275,50	VHH	37	590,25	592,50	UHF
S18	280,25	282,50	VHH	38	597,25	599,50	UHF
S19	287,25	289,50	VHH	39	604,25	606,50	UHF
S20	294,25	296,50	VHH	40	611,25	613,50	UHF
S21	303,25	305,50	VHH	41	618,25	620,50	UHF

## B/B AUSTRALIA STANDARD (CONTINUED)

CHAN.	IMAGE FREQ.	CENTER FREQ.	BAND
42	625,25	627,50	UHF
43	632,25	634,50	UHF
44	639,25	641,50	UHF
45	646,25	648,50	UHF
46	653,25	655,50	UHF
47	660,25	662,50	UHF
48	667,25	669,50	UHF
49	674,25	676,50	UHF
50	681,25	683,50	UHF
51	688,25	690,50	UHF
52	695,25	697,50	UHF
53	702,25	704,50	UHF
54	709,25	711,50	UHF
55	716,25	718,50	UHF
56	723,25	725,50	UHF
57	730,25	732,50	UHF
58	737,25	739,50	UHF
59	744,25	746,50	UHF
60	751,25	753,50	UHF
61	758,25	760,50	UHF
62	765,25	767,50	UHF
63	772,25	774,50	UHF
64	779,25	781,50	UHF
65	786,25	788,50	UHF
66	793,25	795,50	UHF
67	800,25	802,50	UHF
68	807,25	809,50	UHF
69	814,25	816,50	UHF
70	821,25	823,50	UHF
71	828,25	830,50	UHF
72	835,25	837,50	UHF
73	842,25	844,50	UHF
74	849,25	851,50	UHF
75	856,25	858,50	UHF